

SPECIFICATION

For

APPROVAL

- () Preliminary Specification
 () Final Specification

Title	6.4" VGA TFT LCD
--------------	-------------------------

BUYER NAME	
MODEL NAME	

SUPPLIER	LG Philips LCD
MODEL NAME	LP064V1

SIGNATURE	DATE
Please return 1 copy for our confirmation with your signature and comments.	

SIGNATURE	DATE
APPROVED BY	
REVIEWED BY	
PREPARED BY	
10. FEB 1998	
Product Engineering Dept. LG Philips LCD	

TABLE of CONTENTS

NO.	ITEM	Page
-	COVER	1/21
-	TABLE of CONTENTS	2/21
-	RECORD of REVISION	3/21
1.	GENERAL DESCRIPTION	4/21
2.	MAXIMUM RATINGS	5/21
3.	ELECTRICAL SPECIFICATIONS	5/21
4.	OPTICAL SPECIFICATIONS	6/21
5.	INTERFACE CONNECTIONS	7/21
6.	SIGNAL TIMING SPECIFICATIONS	9/21
7.	SIGNAL TIMING WAVE FORMS	10/21
8.	COLOR INPUT DATA REFERENCE	11/21
9.	POWER SEQUENCE	12/21
10.	MECHANICAL CHARACTERISTICS	13/21
11.	RELIABILITY	15/21
12.	INTERNATIONAL STANDARDS	16/21
13.	DESIGNATION OF LOT MARK	17/21
14.	PACKING FORM	17/21
15	HANDLING PRECAUTIONS	18/21
-	APPENDIX	20/21

Record of Revision

DATE AND VERSION	DESCRIPTION

1. General Description

The LG Electronics' model LP064V1 LCD is a Color Active Matrix Liquid Crystal Display with an integral Cold Cathode Fluorescent Tube(CCFT) back light system. The matrix employs a-Si Thin Film Transistor as the active element. It is a transmissive type display operating in the normally white mode. This TFT-LCD has a 6.4 inch diagonally measured active display area with VGA resolution(480 vertical by 640 horizontal pixel array). Each pixel is divided into Red, Green and Blue sub-pixels or dots which are arranged in vertical stripes. Gray scale or the brightness of the sub-pixel color is determined with a 6-bit gray scale signal for each dot, thus, presenting a palette of more than 262,144 colors.

The LP064V1 LCD is intended to support applications where low power consumption, weight and thickness are critical factors and graphic displays are important. In combination with the vertical arrangement of the sub-pixels, the LP064V1 characteristics provide an excellent flat panel display for office automation products such as portable computers and NTSC application.

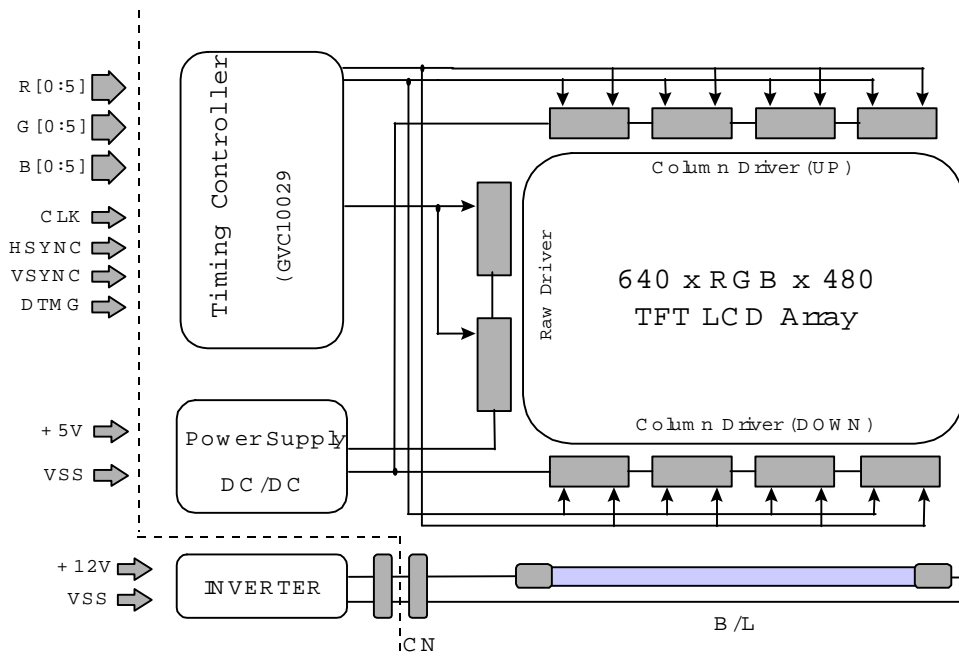

General Display Characteristics

The following are general feature of the model LP064V1 LCD;

Active display area	6.4 inches(cm) diagonal
Outside dimensions	168W x 123 H x 9.0D mm Typ.
Pixel pitch	0.204 mm * 0.204 mm
Pixel format	640 hor. By 480 ver. Pixels RGB stripe arrangement
Color depth	6-bit
Display operating mode	transmissive mode, normally white
Surface treatment	hard coating(2H), anti-glare treatment of the front polarizer

2. Maximum Ratings

The following are maximum values which, if exceeded, may cause faulty operation or damage to the unit.

Table 1 ABSOLUTE MAXIMUM RATINGS

Parameter	symbol	Values		Units	Notes
		Min.	Max.		
Power Input Voltage	V_{DD}	-0.5	+5.5	Vdc	at 25
Logic Input Voltage	$V_{L/H}$	0	$V_{DD}+0.5$	Vdc	at 25
Operating Temperature	T_{OP}	0	+50		1
Storage Temperature	T_{ST}	-20	+60		1

Note: 1. The Relative Humidity must not exceed 80% non-condensing at temperatures of 50 or less.

At temperatures greater than 40 , the wet bulb temperature must not exceed 49 .

At low temperature the brightness of CCFT drop and the life time of CCFT become to be short.

2. Under no condition should the unit be exposed to corrosive chemicals.

3. Electrical Specifications

The LP064V1 requires two power inputs. One is employed to power the LCD electronics and to derive the voltages to drive the TFT array and liquid crystal. The second input which powers the backlight CCFT, is typically generated by an inverter. The inverter is an external unit to the LCD.

Table 2 ELECTRICAL CHARACTERISTICS:

Parameter	Symbol	Values			Units	Notes
		Min.	Typ.	Max.		
MODULE:						
Power Supply Input Voltage	V_{DD}	4.5	5.0	5.5	Vdc	
Power Supply Input Current	I_{DD}	-	180	280	mA	1
Ripple/Noise	-	-	-	60	mV	
Logic Input Level, High	V_{IH}	$0.7V_{DD}$	-	V_{DD}	Vdc	2
Logic Input Level, Low	V_{IL}	V_{SS}	-	$0.3V_{DD}$	Vdc	2
Power Consumption	P	-	0.9	1.54	W	1
BACKLIGHT						
Backlight Input voltage	V_{BL}	-	355	385	V_{RMS}	3
Backlight Current	I_{BL}	3.0	5.0	9.0	mA	
Lamp Kick-Off Voltage		-	-	680	V_{RMS}	25 2
		-	-	860		0
Operating Frequency	F_{BL}	35	55	80	KHz	

Notes: 1. The current draw and power consumption specified is for 5.0Vdc at 25 and 25MHz(DCLK).

Typical power consumption check pattern is 8 gray scale bar.

2. Logic levels are specified for V_{DD} of 5.0 Vdc at 25 .

The values specified apply to all Logic inputs; Hsync, Vsync, clock, data signals, etc.

3. The backlight power consumption shown above does not include loss of external inverter.

4. Optical Specifications

Optical characteristics are determined after the unit has been 'ON' and stable for approximately 30 minutes in a dark environment at 25 °C. The values specified are at an approximate distance 50cm from the LCD surface at a viewing angle of Φ and θ equal to 0°.

Appendix A presents additional information concerning the specified characteristics.

Table 2 OPTICAL CHARACTERISTICS

Parameter	Symbol	Values			Units	Notes
		Min.	Typ.	Max.		
Contrast Ratio	CR	100	-	-		1
Surface Brightness, white (IBL=5.0mA)	SB _{WH}	100	150	-	cd/m ²	2
Brightness Variation	SB _V	-	-	1.4		3
Response Time						
Rise Time	Tr _R		20	50	msec	4
Decay Time	Tr _D	-	35	50	msec	4
CIE Color Coordinates						
Red	x _R	0.557	0.587	0.617		5
	y _R	0.322	0.352	0.382		5
Green	x _G	0.254	0.284	0.314		5
	y _G	0.522	0.552	0.582		5
Blue	x _B	0.114	0.144	0.174		5
	y _B	0.092	0.122	0.152		5
White	x _W	0.292	0.322	0.352		5
	y _W	0.289	0.319	0.349		5
Viewing Angle (CR>10:1)						
x axis, right ($\theta = 0^\circ$)				40	degree,	6
x axis, left ($\theta = 180^\circ$)				40		
y axis, up ($\theta = 90^\circ$)				10		
y axis, down ($\theta = 270^\circ$)				30		

Notes 1. Contrast Ratio (CR) is defined mathematically as:

$$\text{Contrast Ratio (CR)} = \frac{\text{Surface Brightness with all white pixels}}{\text{Surface Brightness with all black pixels}}$$

2. Surface brightness is the center of 5 points (this means number 3 in Appendix A-1 Brightness) across the LCD surface 50cm from the surface with all pixels displaying white. For more information see Appendix A..

3. The Variation in surface brightness, SB_V is determined by measuring B_{ON} at each test position 1 through 5, and then dividing the maximum B_{ON} by the minimum B_{ON}.

$$\text{SB}_V = \frac{\text{Maximum (B}_{ON1}, \text{B}_{ON2}, \dots, \text{B}_{ON5})}}{\text{Minimum (B}_{ON1}, \text{B}_{ON2}, \dots, \text{B}_{ON5})}}$$

4. Response time is the time required for the display to transition from white to black (Rise Time, Tr_R) and from black to white (Decay Time, Tr_D). For additional information see Appendix A.

5. Color Coordinates is unfixed

6. Viewing angle is the angle at which the contrast ratio is greater than 10. The angles are determined for the horizontal or x axis and the vertical or y axis with respect to the z axis which is normal to the LCD surface. For more information see Appendix A.

5. Interface Connections

This LCD employs two interface connections, a 31 pin connector is used for the module and a three pin connector is used for the integral backlight system.

The electric interface connector is a model DF9B-31P-1V, manufactured by Hirose. The mating connector part number is DF9-31S-1V or equivalent. The pin configuration for the connector is shown in the table below.

Table 3 MODULE CONNECTOR PIN CONFIGURATION

Pin	Symbol	Description	Notes
1	Vss	Ground	Connect to Vss, see Note 1
2	CLK	Main clock	
3	Hsync	Horizontal sync.	
4	Vsync	Vertical sync.	
5	Vss	Ground	Connect to Vss, see Note 1
6	R0	Red data	Red data least significant bit(LSB)
7	R1	Red data	
8	R2	Red data	
9	R3	Red data	
10	R4	Red data	
11	R5	Red data	Red data most significant bit(MSB)
12	Vss	Ground	Connect to Vss, see Note 1
13	G0	Green data	Green data least significant bit(LSB)
14	G1	Green data	
15	G2	Green data	
16	G3	Green data	
17	G4	Green data	
18	G5	Green data	Green data most significant bit(MSB)
19	Vss	Ground	Connect to Vss, see Note 1
20	B0	Blue data	Blue data least significant bit(LSB)
21	B1	Blue data	
22	B2	Blue data	
23	B3	Blue data	
24	B4	Blue data	
25	B5	Blue data	Blue data most significant bit(MSB)
26	Vss	Ground	
27	DTMG	Data Timing Signal	
28	Vdd	Power(+5V)	Connect to Vdd, see Note 2
29	Vdd	Power(+5V)	Connect to Vdd, see Note 2
30	OAS	O/A, A/V Selection	see Note3
31	NC	No Connection	

Notes: 1. All GND(ground) pins should be connected together and to Vss which should also be connected to the LCD's metal frame.

2. All V_{DD}(power input) pins should be connected together.

3. This pin is Logic input pin and is connected V_{DD}(power input) with surge protection circuit.

4. DTMG, HSYNC and VSYNC shall be supplied simultaneously.

Product Specification

The backlight interface connector is a model BHR-03VS-1, manufactured by JST. The mating connector part number is SM02(8.0)B-BHS-1-TB or equivalent. The pin configuration for the connector is shown in the table below.

Table 4 BACKLIGHT CONNECTOR PIN CONFIGURATION

Pin	Symbol	Description	Notes
1	HV	Lamp power input	1
2	NC	No connect	
3	LV	Ground	

Notes: 1. The input power terminal is colored pink.

6. Signal Timing Specifications

ITEM		Symbol	Value			Units	Notes
			Min.	Typ.	Max.		
DCLK	Period	fCLK	-	(25.18)	28	Mhz	
	Width-Low	tWCL	7	-	-	ns	
	Width-High	tWCH	7	-	-	ns	
	Rise Time	trCLK	7	-	-	ns	
	Fall Time	tfCLK	7	-	-	ns	
	Duty	D	0.45	0.5	0.55	-	D=tCLKL /tCLK
Hsync	Set-up Time	tSH	3	-	-	ns	for DCLK
	Hold Time	tHH	8	-	-	ns	
	Period	tHP	776	(800)	880	tCLK	
	Width-Active	tWH	12	(96)	200	tCLK	
	Rise/Fall Time	tHr,tHf	-	-	30	ns	
Vsync	Set-up Time	tSV	0	-	- -	tCLK	for Hsync
	Hold Time	tHV	2	-	-	tCLK	
	Period	tVP	515	(525)	560	tHP	
	Width-Active	tWV	1	2	34	tHP	
	Rise/Fall Time	tVr,tVf	-	-	50	ns	
DTMG	Set up Time	tSI	3	-	-	ns	for DCLK
	Hold Time	tHI	8	-	-	ns	
	Rise/Fall Time	tlr,tlf	-	-	30	ns	
	Horizontal Back Porch	tHBP	-	48	-	tCLK	
	Horizontal Front Porch	tHFP	-	16	-	tCLK	
	Vertical Back Porch	tVBP	-	32	-	tHP	
	Vertical Front Porch	tVFP	-	11	-	tHP	
DATA	Set up Time	tSD	7	-	-	ns	for DCLK
	Hold Time	tHD	14	-	-	ns	
	Rise/Fall Time	tDr,tDf	-	-	25	ns	

* Setup, Hold, Rise and Fall Times are TBD.

7. Signal Timing Wave Forms

(DATA : Latched at Fall edge of DCLK)

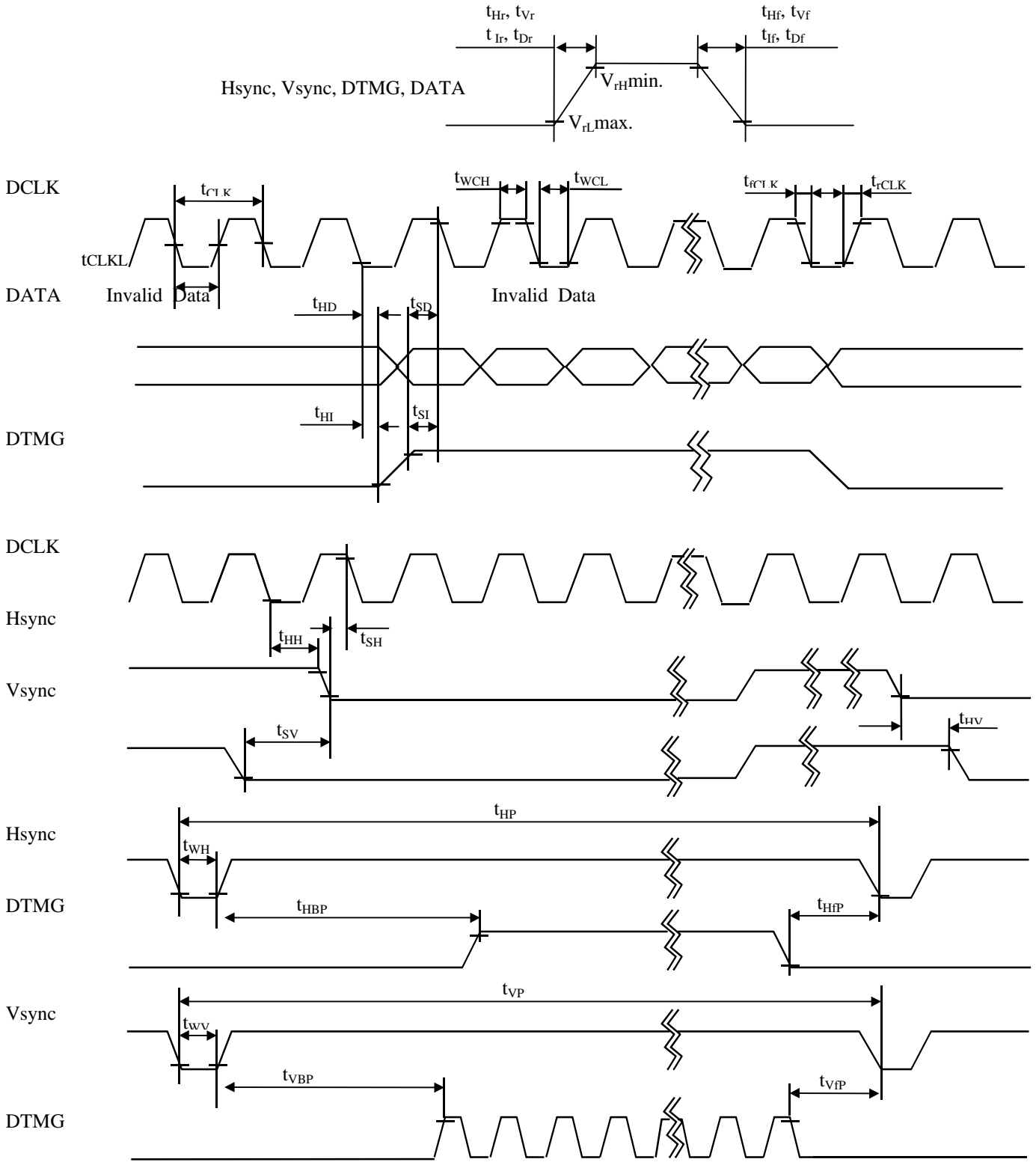

8. Color Input Data Reference

The brightness of each primary color (red, green and blue) is based on the 6-bit gray scale data input for the color; the higher the binary input, the brighter the color. The table below provides a reference for color versus data input.

Table 5 COLOR DATA REFERENCE

Color		Input Color Data																	
		Red						Green						Blue					
		R5	R4	R3	R2	R1	R0	G5	G4	G3	G2	G1	G0	B5	B4	B3	B2	B1	B0
Basic Colors	Black	0	0	0	0	0	0	0	0	0	0	0	0	0	0	0	0	0	0
	Red(63)	1	1	1	1	1	1	0	0	0	0	0	0	0	0	0	0	0	0
	Green(63)	0	0	0	0	0	0	1	1	1	1	1	1	0	0	0	0	0	0
	Blue(63)	0	0	0	0	0	0	0	0	0	0	0	0	1	1	1	1	1	1
	Cyan	0	0	0	0	0	0	1	1	1	1	1	1	1	1	1	1	1	1
	Magenta	1	1	1	1	1	1	0	0	0	0	0	0	1	1	1	1	1	1
	Yellow	1	1	1	1	1	1	1	1	1	1	1	1	0	0	0	0	0	0
	White	1	1	1	1	1	1	1	1	1	1	1	1	1	1	1	1	1	1
Red	Red(00) Black	0	0	0	0	0	0	0	0	0	0	0	0	0	0	0	0	0	0
	Red(01)	0	0	0	0	0	1	0	0	0	0	0	0	0	0	0	0	0	0
	Red(02)	0	0	0	0	1	0	0	0	0	0	0	0	0	0	0	0	0	0
	:	:	:	:	:	:	0	0	0	0	0	0	0	0	0	0	0	0	
	Red(61)	1	1	1	1	0	1	0	0	0	0	0	0	0	0	0	0	0	0
	Red(62)	1	1	1	1	1	0	0	0	0	0	0	0	0	0	0	0	0	0
	Red(63)	1	1	1	1	1	1	0	0	0	0	0	0	0	0	0	0	0	0
Green	Green(00) Black	0	0	0	0	0	0	0	0	0	0	0	0	0	0	0	0	0	0
	Green(01)	0	0	0	0	0	0	0	0	0	0	0	1	0	0	0	0	0	0
	Green(02)	0	0	0	0	0	0	0	0	0	0	1	0	0	0	0	0	0	0
	:	:	:	:	:	:	:	:	:	:	:	:	0	0	0	0	0	0	
	Green(61)	0	0	0	0	0	0	1	1	1	1	0	1	0	0	0	0	0	0
	Green(62)	0	0	0	0	0	0	1	1	1	1	1	0	0	0	0	0	0	0
	Green(63)	0	0	0	0	0	0	1	1	1	1	1	1	0	0	0	0	0	0
Blue	Blue(00) Black	0	0	0	0	0	0	0	0	0	0	0	0	0	0	0	0	0	0
	Blue(01)	0	0	0	0	0	0	0	0	0	0	0	0	0	0	0	0	0	1
	Blue(02)	0	0	0	0	0	0	0	0	0	0	0	0	0	0	0	0	1	0
	:	:	:	:	:	:	0	0	0	0	0	0	:	:	:	:	:	:	
	Blue(61)	0	0	0	0	0	0	0	0	0	0	0	0	1	1	1	1	0	1
	Blue(62)	0	0	0	0	0	0	0	0	0	0	0	0	1	1	1	1	1	0
	Blue(63)	0	0	0	0	0	0	0	0	0	0	0	0	1	1	1	1	1	1

9. Power Sequence

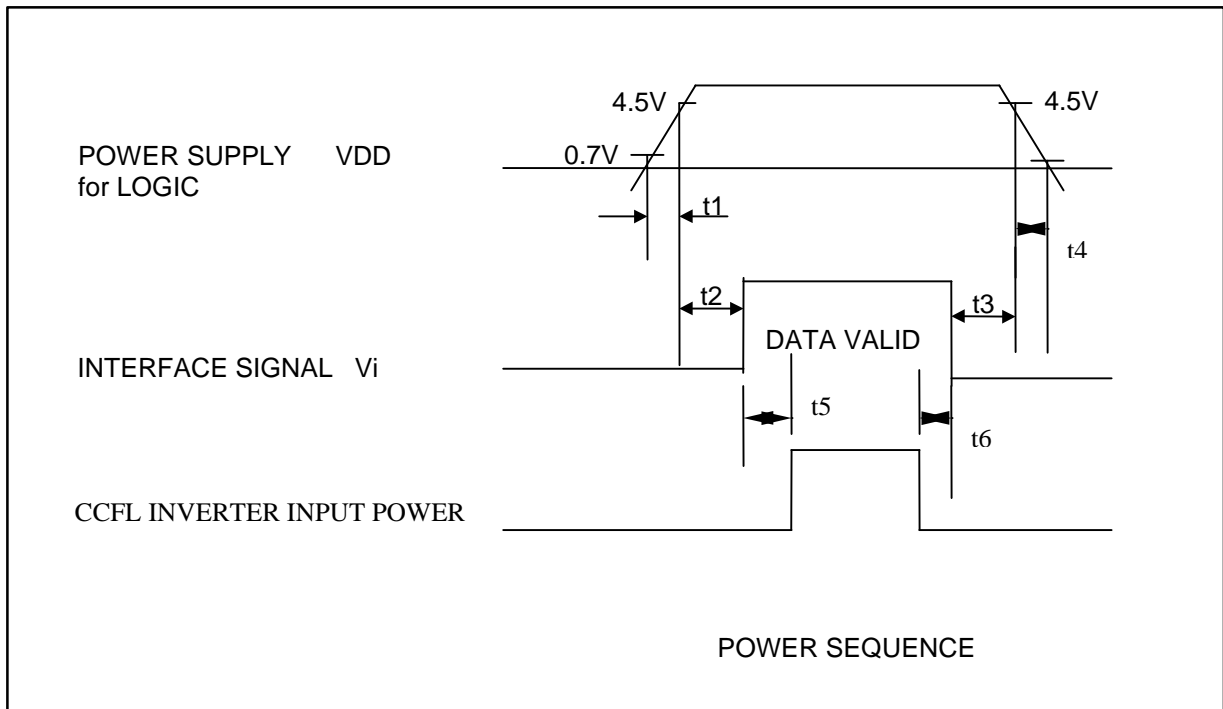

t1 40msec, 0<t2 50msec, 0<t3 50msec, t4<1sec, 0<t5 2 sec, 0<t6 2sec

* Set 0 Volt Vi(t) VDD(t)

Here Vi(t), VDD(t) indicate the transitive state of Vi, VDD when power supply is turned ON or OFF

- Notes :
1. Please avoid floating state of interface signal at invalid period.
 2. When the interface signal is invalid, be sure to pull down the power supply for LCD VDD to 0V.

Product Specification

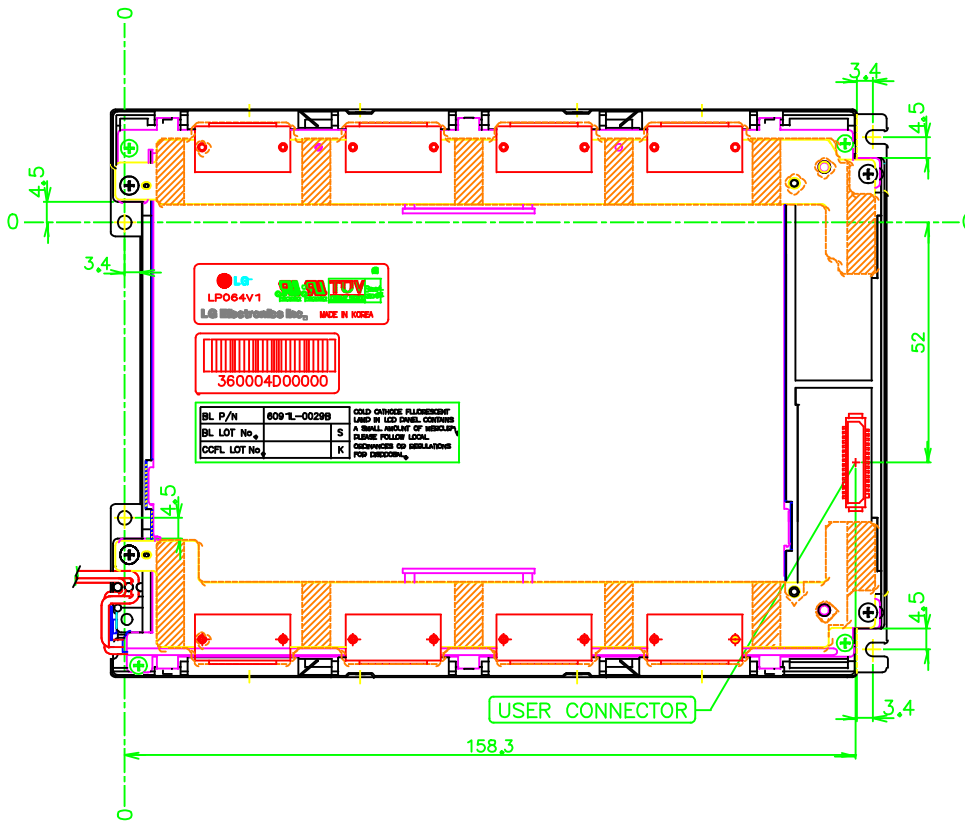

11. Reliability

No.	Test ITEM	Conditions
1	High temperature storage test	Ta = 60 240h
2	Low temperature storage test	Ta = -20 240h
3	High temperature & high humidity operation test	Ta = 40 95% 240h (no condensation)
4	High temperature operation test	Ta = 50 240h
5	Low temperature operation test	Ta = 0 240h
6	Vibration test (non-operating)	Frequency:10~57Hz / Vibration Width(one side):0.075mm :58~500Hz / Gravity:9.8m/s ² Sweep time: 11 minutes Test period: 3 hours (1 hour for each direction of X,Y,Z)
7	Shock test (non-operating)	Max. Gravity: 490m/s Pulse width: 11ms, half sine wave Direction: X, Y, Z one for each direction

{Result Evaluation Criteria}

There should be no change which might affect the practical display function when the display quality test is conducted under normal operating condition.

In High temperature and low temperature operation test, lamp current should be 5 mA.

12. International Standards (TBD)

12.1. Safety

UL1950 Safety of Information Technology Equipment Including Electrical Business Equipment.
Third Edition Underwriters Laboratories, Inc. 1995

CAS C22.2 Safety of Information Technology Equipment Including Electrical Business Equipment.
Third Edition Canadian Standards Association, 1995

EN 60950 Safety of Information Technology Equipment Including Electrical Business Equipment.
European Committee for Electro technical Standardization(CENELEC), 1995
Ref. No. EN 60950: 1992 + A1: 1993 + A2: 1993 + A3: 1995 E
(IEC 950: 1991 + A1: 1992 + A2: 1993 + A3: 1995, modified)

12.2. EMC

ANSI C63.4 Methods of Measurement of Radio-Noise Emissions from Low-Voltage Electrical and
Electronic Equipment in the Range of 9kHz to 40GHz.
American National Standards Institute(ANSI),1992.

C.I.S P.R Limits and Methods of Measurement of Radio Interference Characteristics of
D.Information

Technology Equipment. International Special Committee on Radio Interference

EN 55 022 Limits and Methods of Measurement of Radio Interference Characteristics of Information
Technology Equipment. European Committee for Electro technical Standardization
(CENELEC),1988

Product Specification

13. Designation of Lot Mark

13.1. Lot Mark



1) 2)

A, B : SBU CODE (TBD)
 C, D, E : MODEL CODE
 F : YEAR
 G : MONTH
 H, I, J, K : SERIAL NO.

NOTE 1) YEAR

YEAR	89	90	91	92	93	94	95	96	97	98	99
Mark	9	0	1	2	3	4	5	6	7	8	9

NOTE 2) MONTH

MONTH	Jan.	Feb.	Mar.	Apr.	May.	Jun.	Jul.	Aug.	Sep.	Oct.	Nov.	Dec.
Mark	1	2	3	4	5	6	7	8	9	O	N	D

13.2. Location of Lot Mark

Serial NO. is printed on the label. The label is attached to the backside of the backlight unit. This is subjected to change without prior notice.

14. Packing Form

- a) Package quantity in the box : TBD
- b) Box size : TBD

15. Handling Precautions

Please pay attention to the followings when you use this TFT/LCD module with Back-light unit.

15.1.MOUNTING PRECAUTION

1) You must mount Module using mounting holes arranged in 4 corners.

Be sure to turn off the power when connecting or disconnecting the circuit.

2) Note that the polarizers are easily damaged. Pay attention not to scratch or press this surface with any hard object.

3) When the LCD surface become dirty, please wipe it off with a soft material. (ie.cottonball)

Protect the module from the ESD as it may damage the electronic circuit (C-MOS). Make certain that treatment person's body are grounded through wrist bend.

4) Protect the module from the ESD as it may damage the electric circuit(C_MOS).

Make certain that treatment person's body are grounded through wrist bend.

5) Do not disassemble the module and be careful not to incur a mechanical shock that might occur during installation. It may cause permanent damage.

6) Do not leave the module in high temperatures, Particularly in areas of high humidity for a long time.

7) The module not be expose to the direct sunlight.

8) Avoid contact with water as it may a short circuit within the module.

15.2. OPERATING PRECAUTION

1) The spike noise causes the mis-operation of circuits.

Be lower the spike noise as follows :

VDD= 200mV, V1= 200mV(Over and under shoot voltage.)

2) Response time depends on the temperature. (In lower temperature, it becomes longer.)

3) Brightness depends on the temperature. (In lower temperature, it becomes lower.)

And in lower temperature, response time (Required time that brightness is stable after turn on)becomes longer.

4) Be careful for condensation at suddern temperature change. Condensation make damage to polarizer or electrical contact part. And after fading condensation, smear or spot will occur.

5) When fixed pattern are displayed at long times, remnant image is likely to occur.

6) Module has high frequency circuit. If you need to shield the electromagnetic noise.

Please do in yours.

7) When Back-light unit is operating, it sounds.

If you need to shield the noise, please do in yours.

15.3 ELECTROSTATIC DISCHARGE CONTROL

Since module is composed with electronic circuit, it is not strong to electrostatic discharge. Make certain that treatment persons are connected to ground through list band etc.. And don't touch I/F pin directly.

15.4 PRECAUTION FOR STRONG LIGHT EXPOSURE.

Strong light exposure causes degradation of polarizer and color filter.

15.5 STORAGE

When storing module as spares for long time, the following precautions are necessary.

- 1) Store them in a dark place : do not expose them to sunlight or fluorescent light. Keep the temperature between 5 and 35 at normal humidity.
- 2) The polarizer surface should not come in contact with any other object. It is recommended that they be stored in the container in which they were shipped.

15.6 HANDLING PRECAUTIONS FOR PROTECTION FILM

- 1) When the protection film is peeled off, static electricity is generated between the film and the polarizer. This film should be peeled off slowly and carefully by people who are electrically grounded and with well ion-blown equipment or in such a condition. etc.
- 2) The protection film is attached the polarizer with a small amount of glue.If some stress is applied to rub the protection film against the polarizer during the time you peel off the film, the glue is apt to remain more on the polarizer. So please carefully peel off the protection film without rubbing it against the polarizer.
- 3) When the module with protection film attached is stored for long time, sometimes there remains a very small amount of glue still on the polarizer after the protection film is peeled off. Please refrain from storing the module at the high temperature and high humidity for glue is apt to remain in these condition.
- 4) The glue may be taken for the modules failure, but you can remove the glue easily. When the glue remains on the polarizer surface or its vestige is recognized, please wipe them off with absorbent cotton waste or other soft material like chamois soaked with Normal-hexane.

15.7 SAFETY

- 1) If module is broken, be careful to handle not to injure. (TFT/LCD and lamp are made of glass)
Please wash hands sufficiently when you touch the liquid crystal coming out from broken LCDs.
- 2) As it is possible for PCB or other electronic parts of module to small to smoke and to take fire because of the short circuit. Please design the circuit of your instrument not to flow the electric current to TFT/LCD module more than 500mA. (by apply the fuse for example)
- 3) As Back-light unit has high voltage circuit internal, do not open the case and do not insert foreign materials in the case.

Product Specification

A-1 Brightness

<measuring point>

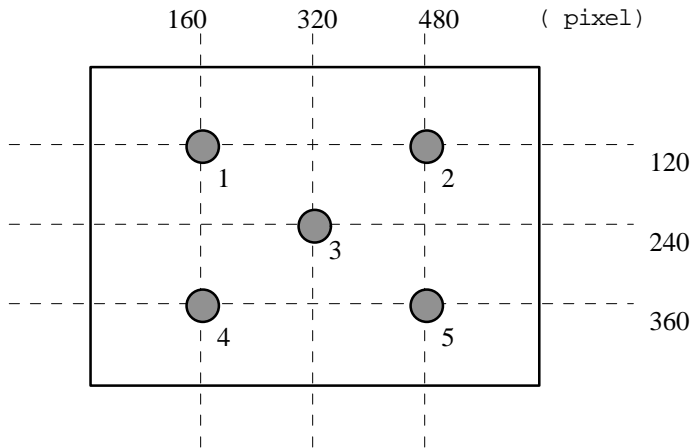

A-2 RESPONSE TIME

The response time is defined as the following figure and shall be measured by switching the input signal for black and white .

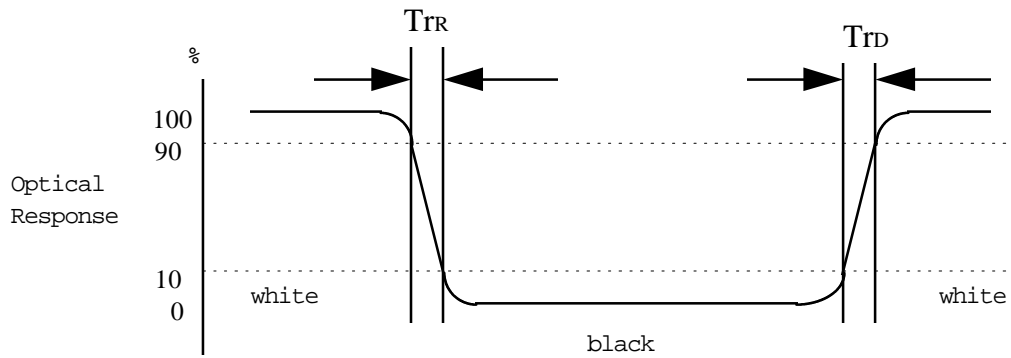

Product Specification

A-3 Viewing angle

<Definition of viewing angle range>

