

DEVICE SPECIFICATION

**TFT-LCD Module**

MODEL

**LQ0DZA0115**



## **1. Application**

This specification applies to color TFT-LCD module, LQ0DZA0115.

The device listed in these specification sheets was designed and manufactured for use in general electronic equipment.

In case of using the device for applications such as control and safety equipment for transportation (aircraft, trains, automobiles, etc.), rescue and security equipment and various safety related equipment which require higher reliability and safety, take into consideration that appropriate measures such as fail-safe functions and redundant system design should be taken.

Do not use the device for equipment that requires an extreme level of reliability, such as aerospace applications, telecommunication equipment (trunk lines), nuclear power control equipment and medical or other equipment for life support.

## 2. Overview

This module is a color active matrix LCD module incorporating amorphous silicon TFT (Thin Film Transistor). It is composed of a color TFT-LCD panel, driver ICs, control circuit and power supply circuit and a backlight unit. Graphics and texts can be displayed on a  $800 \times 3 \times 600$  dots panel with about 12-million-color by using LVDS (Low Voltage Differential Signaling) system for interface and supplying +3.3V DC supply voltage for TFT-LCD panel driving and supply voltage for backlight.

The TFT-LCD panel used for this module is a low-reflection and higher-color-saturation type.

Therefore, this module is also suitable for the multimedia use. Viewing angle is 6 o'clock direction.

Backlight-driving DC/AC inverter is not built in this module.

## 3. Outline Specifications

| Parameter                  | Specifications  | Unit  |
|----------------------------|---|-------|
| Display size               | 31 (12.1") Diagonal   | cm    |
| Active area                | 246.0 (H) × 184.5 (V)   | mm    |
| Pixel format               | 800 (H) × 600 (V)   | pixel |
|                            | (1 pixel=R+G+B dots)  |       |
| Aspect ratio               | 4 : 3   |       |
| Pixel pitch                | 0.3075 (H) × 0.3075 (V)   | mm    |
| Pixel configuration        | R,G,B vertical stripe   |       |
| Display mode               | Normally white  |       |
| Unit outline dimensions *1 | 276.0(W) × 209.0(H) × Max.11.0 (D)<br>*Outline dimensions is shown in Fig.1 | mm    |
| Mass                       | MAX. 660  | g     |
| Surface treatment          | Anti-glare and hard-coating 3H  |       |

[\*1 Note] excluding backlight cables.

#### 4. Input Terminals

##### 4-1. TFT-LCD panel driving

CN1 (LVDS signals , +3.3V DC power supply and Control signal)

Corresponding connector: DF14-20S-1.25C(Connector) [Hirose electric.,Ltd]  
DF14-2628SCF(Terminal) [Hirose electric.,Ltd]

| Pin No. | Symbol          | Function                                       | Remark      |
|---------|-----------------|--|-------------|
| 1       | V <sub>CC</sub> | +3.3V power supply                             |             |
| 2       | V <sub>CC</sub> | +3.3V power supply                             |             |
| 3       | GND             |  |             |
| 4       | GND             |  |             |
| 5       | RXIN0-          | Differential data input, CH0 (negative)        | LVDS signal |
| 6       | RXIN0+          | Differential data input, CH0 (positive)        | LVDS signal |
| 7       | GND             |  |             |
| 8       | RXIN1-          | Differential data input, CH1 (negative)        | LVDS signal |
| 9       | RXIN1+          | Differential data input, CH1 (positive)        | LVDS signal |
| 10      | GND             |  |             |
| 11      | RXIN2-          | Differential data input, CH2 (negative)        | LVDS signal |
| 12      | RXIN2+          | Differential data input, CH2 (positive)        | LVDS signal |
| 13      | GND             |  |             |
| 14      | RXCLK IN-       | Differential clock input (negative)            | LVDS signal |
| 15      | RXCLK IN+       | Differential clock input (positive)            | LVDS signal |
| 16      | GND             |  |             |
| 17      | RXIN3-          | Differential data input, CH3 (negative)        | LVDS signal |
| 18      | RXIN3+          | Differential data input, CH3 (positive)        | LVDS signal |
| 19      | RL/UD           | Horizontal/Vertical display mode select signal | [Note1]     |
| 20      | SELLVDS         | Select LVDS                                    | [Note2]     |

[Note 1]

RL/UD = Low

RL/UD = High

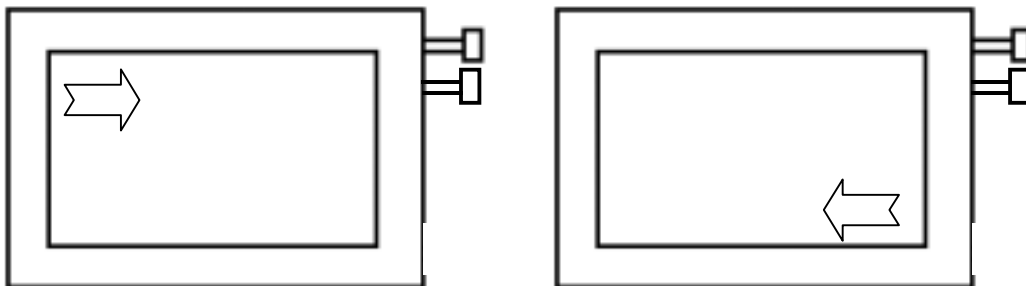

[Note 2] Relation between LVDS signals and actual data shows below section (4- 4)

## 4-2 Data Mapping

## 1) 8 bit input

【note2】 pin assignment with LVDS\_SET pin (Thine:THC63LVDM83R)

| Transmitter |      | 20pin LVDS_SET   |           |
|-------------|------|------------------|-----------|
| Pin No      | Data | =L (GND) or Open | =H (3.3V) |
| 51          | TA0  | R0 (LSB)         | R2        |
| 52          | TA1  | R1               | R3        |
| 54          | TA2  | R2               | R4        |
| 55          | TA3  | R3               | R5        |
| 56          | TA4  | R4               | R6        |
| 3           | TA5  | R5               | R7 (MSB)  |
| 4           | TA6  | G0 (LSB)         | G2        |
| 6           | TB0  | G1               | G3        |
| 7           | TB1  | G2               | G4        |
| 11          | TB2  | G3               | G5        |
| 12          | TB3  | G4               | G6        |
| 14          | TB4  | G5               | G7 (MSB)  |
| 15          | TB5  | B0 (LSB)         | B2        |
| 19          | TB6  | B1               | B3        |
| 20          | TC0  | B2               | B4        |
| 22          | TC1  | B3               | B5        |
| 23          | TC2  | B4               | B6        |
| 24          | TC3  | B5               | B7 (MSB)  |
| 27          | TC4  | (NA)             | (NA)      |
| 28          | TC5  | (NA)             | (NA)      |
| 30          | TC6  | DE               | DE        |
| 50          | TD0  | R6               | R0 (LSB)  |
| 2           | TD1  | R7 (MSB)         | R1        |
| 8           | TD2  | G6               | G0 (LSB)  |
| 10          | TD3  | G7 (MSB)         | G1        |
| 16          | TD4  | B6               | B0 (LSB)  |
| 18          | TD5  | B7 (MSB)         | B1        |
| 25          | TD6  | (NA)             | (NA)      |

< LVDS\_SET = L or Open >

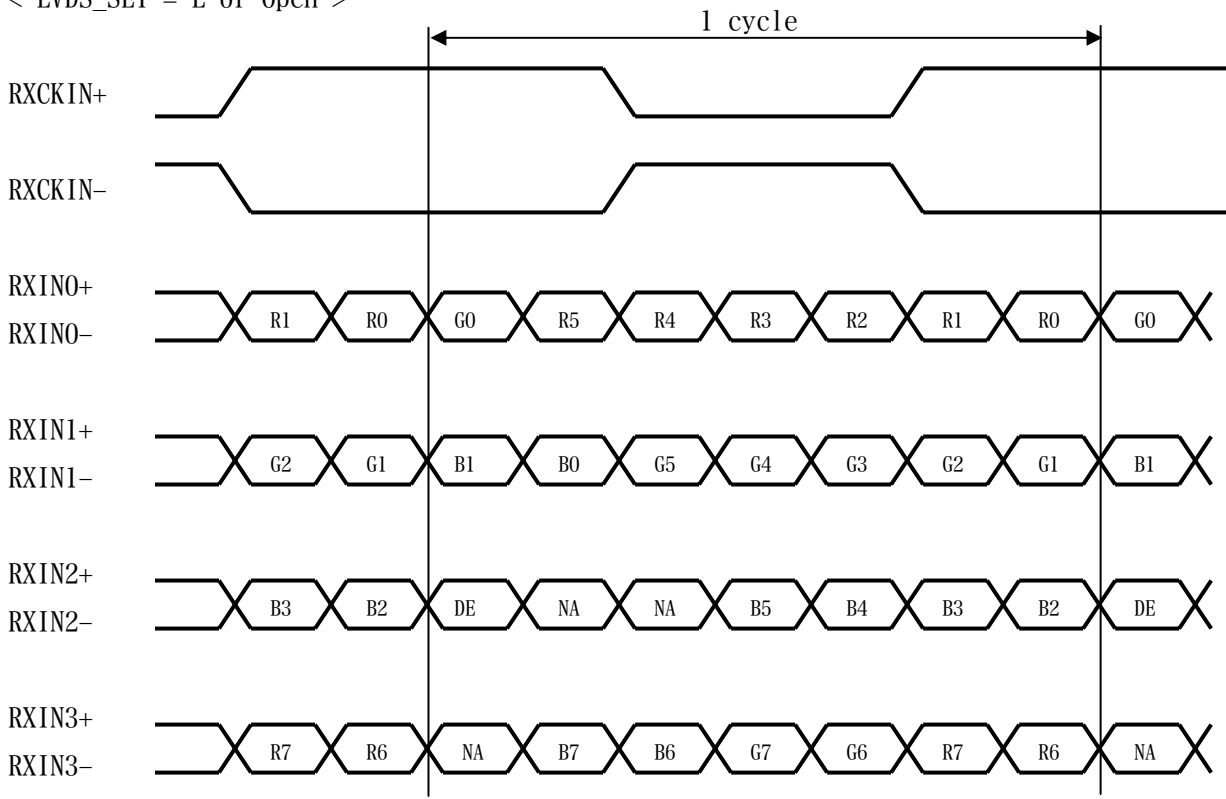

DE: Display Enable  
 NA: Not Available

< LVDS\_SET = H >

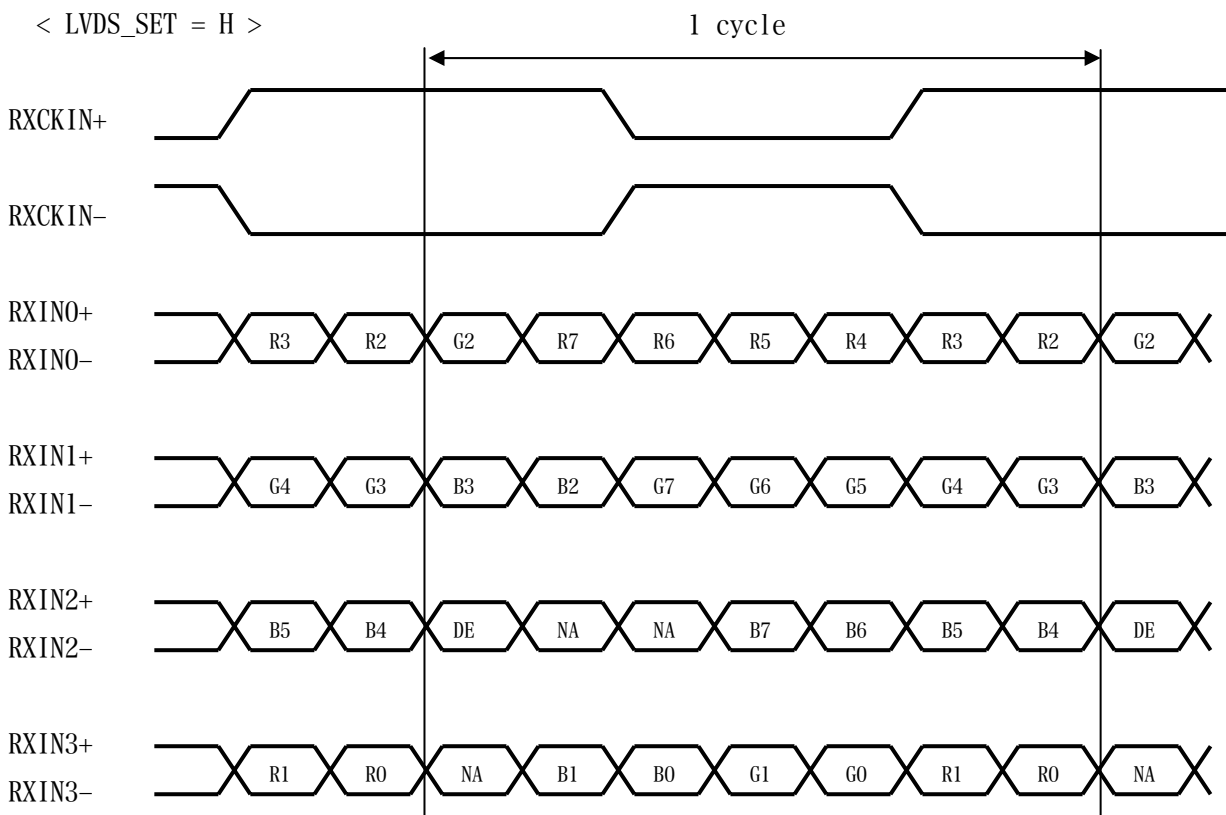

DE: Display Enable  
 NA: Not Available

## 2) 6 bit input

【note2】 pin assignment with LVDS\_SET pin (Thine:THC63LVDM83R)

| Transmitter |      | 20pin LVDS_SET   |           |
|-------------|------|------------------|-----------|
| Pin No      | Data | =L (GND) or Open | =H (3.3V) |
| 51          | TA0  | —                | R0 (LSB)  |
| 52          | TA1  | —                | R1        |
| 54          | TA2  | —                | R2        |
| 55          | TA3  | —                | R3        |
| 56          | TA4  | —                | R4        |
| 3           | TA5  | —                | R5 (MSB)  |
| 4           | TA6  | —                | G0 (LSB)  |
| 6           | TB0  | —                | G1        |
| 7           | TB1  | —                | G2        |
| 11          | TB2  | —                | G3        |
| 12          | TB3  | —                | G4        |
| 14          | TB4  | —                | G5 (MSB)  |
| 15          | TB5  | —                | B0 (LSB)  |
| 19          | TB6  | —                | B1        |
| 20          | TC0  | —                | B2        |
| 22          | TC1  | —                | B3        |
| 23          | TC2  | —                | B4        |
| 24          | TC3  | —                | B5 (MSB)  |
| 27          | TC4  | —                | (NA)      |
| 28          | TC5  | —                | (NA)      |
| 30          | TC6  | —                | DE        |
| 50          | TD0  | —                | GND       |
| 2           | TD1  | —                | GND       |
| 8           | TD2  | —                | GND       |
| 10          | TD3  | —                | GND       |
| 16          | TD4  | —                | GND       |
| 18          | TD5  | —                | GND       |
| 25          | TD6  | —                | (NA)      |

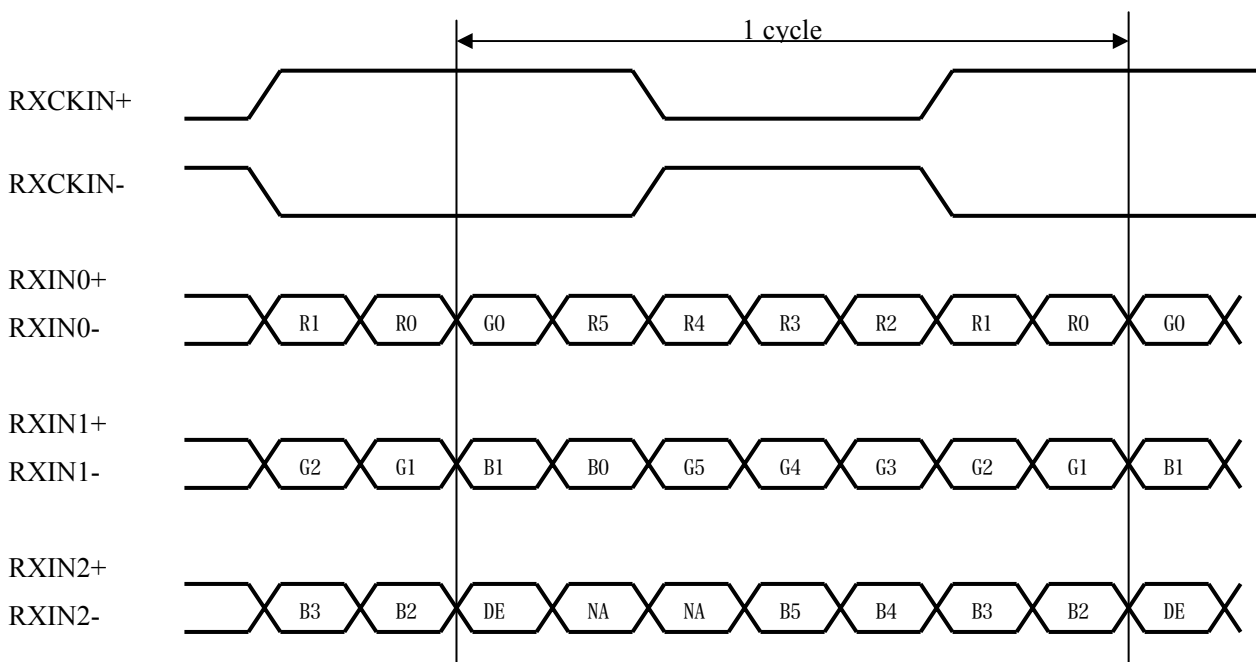

DE: Display Enable

NA: Not Available



(Computer side)

(TFT-LCD side)

①8Bit Mode

LVDS\_SET=L (20 pin=GND or OPEN)

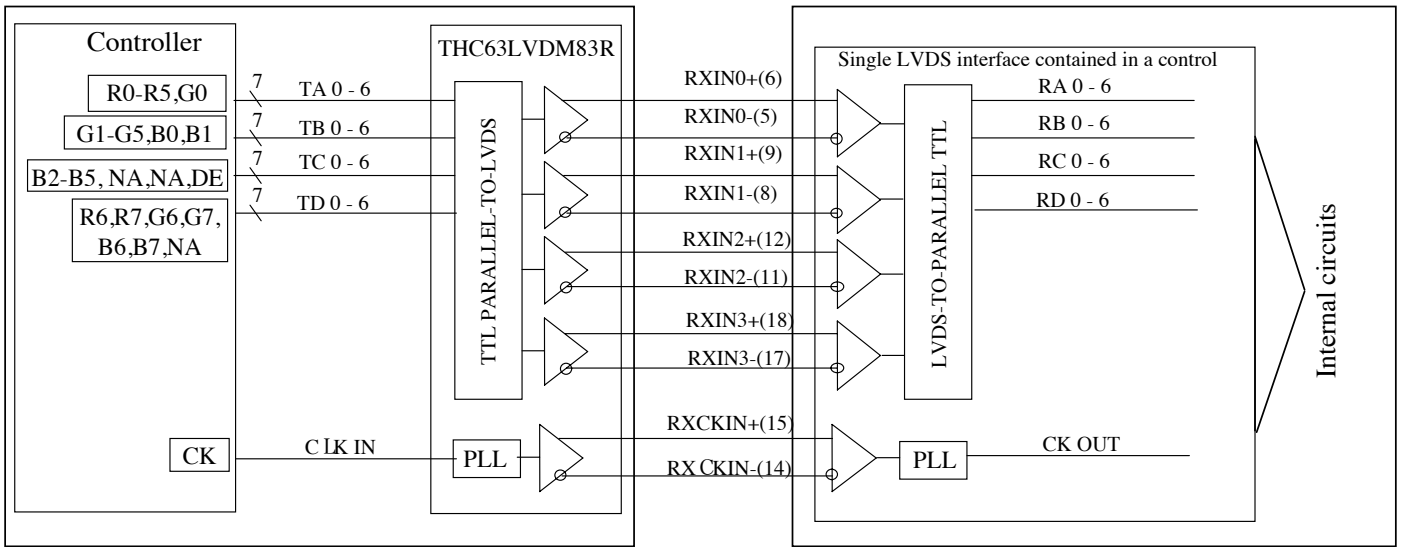

②8Bit Mode

LVDS\_SET=H (20 pin=3.3[V])

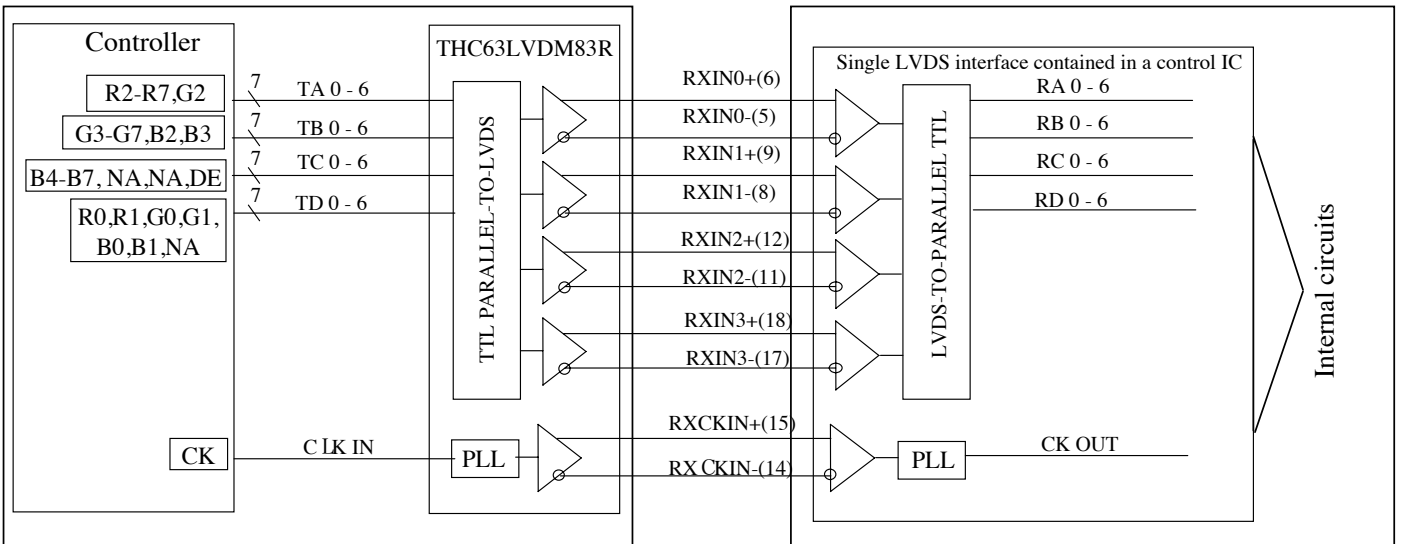

③6Bit Mode

LVDS\_SET=H (20 pin=3.3[V])

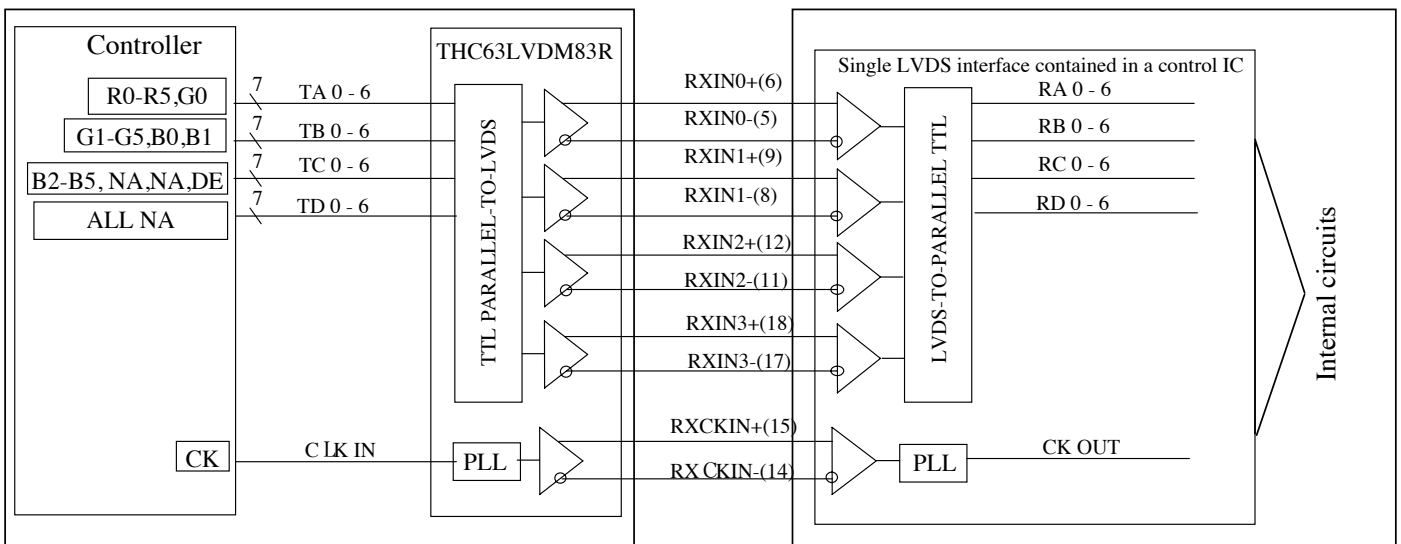

#### 4-4. Backlight driving CN2 ,CN3

Used connector: BHR-02(8.0)VS-1N (JST)  
Corresponding connector: SM02(8.0)B-BHS-1R-TB(JST)  
SM02(8.0)B-BHS-1-TB (JST)

| Connector No. | Pin No. | Symbol            | function                                  | FL Cable color |       |
|---------------|---------|-------------------|---|----------------|-------|
|               |         |                   |   | CN2            | CN3   |
| CN2,3         | 1       | V <sub>HIGH</sub> | Power supply for lamp (High voltage side) | White          | Pink  |
|               | 2       | V <sub>LOW</sub>  | Power supply for lamp (Low voltage side)  | Gray           | White |

#### 5. Absolute Maximum Ratings

| Parameter             | Symbol            | Condition            | Pin name  | Ratings                      | Unit             | Remark    |
|-----------------------|-------------------|----------------------|---|------------------------------|------------------|-----------|
| supply voltage        | V <sub>cc</sub>   | T <sub>a</sub> =25°C | V <sub>cc</sub>                                 | -0.3 to 4.0                  | V                | [Note1,4] |
| Input voltage         | V <sub>I1</sub>   | T <sub>a</sub> =25°C | RXIN <sub>i</sub> -/(i= 0,1,2,3)<br>RXCLK IN-/+ | -0.3 to V <sub>cc</sub> +0.3 | V                |           |
|                       | V <sub>I2</sub>   | T <sub>a</sub> =25°C | RL/UD,SELLVDS                                   | -0.3 to V <sub>cc</sub> +0.3 | V                |           |
| Lump input voltage    | V <sub>HIGH</sub> | -                    | V <sub>HIGH</sub> (CN2,CN3)                     | 0 to +2000                   | V <sub>rms</sub> | [Note1,2] |
| Storage temperature   | T <sub>stg</sub>  | -                    | -   | -30 to +75                   | °C               | [Note1]   |
| Operating temperature | T <sub>opa</sub>  | Ambient              | -   | -10 to<br>+75(panel surface) | °C               | [Note1,3] |

[Note1] Humidity: 95%RH Max. at T<sub>a</sub><=40°C.

Maximum wet-bulb temperature at 39°C or less at T<sub>a</sub>>40°C.

No condensation.

[Note2]A high voltage should be not able to be continued when the lamp doesn't light

[Note3] When used on condition of Operating temperature [ $65^{\circ}\text{C} \leq T_{\text{OPA}} < 75^{\circ}\text{C}$ ],

degradation of display grace, such as screen stain etc, may be caused.

[Note4]Please use the one of 2A or more in current capacity about the power-supply voltage.

**6. Electrical Characteristics**

6-1.TFT-LCD panel driving

Ta=+25 °C

| Parameter                            |                        | Symbol          | Min.                 | Typ. | Max.                 | Unit  | Remark                           |
|--------------------------------------|------------------------|-----------------|----------------------|------|----------------------|-------|----------------------------------|
| Supply voltage                       |                        | V <sub>CC</sub> | +3.0                 | +3.3 | +3.6                 | V     | [Note4]                          |
| Current dissipation                  | V <sub>CC</sub> =+3.3V | I <sub>CC</sub> | -                    | 350  | 450                  | mA    | [Note5]                          |
| Input voltage range                  | LVDS signal            | V <sub>L</sub>  | 0                    | -    | 2.4                  | V     | [Note3]                          |
| Permissive input ripple voltage      | V <sub>CC</sub> =+3.3V | V <sub>RP</sub> | -                    | -    | 100                  | mVp-p |                                  |
| Differential input threshold voltage | High                   | V <sub>TH</sub> | -                    | -    | V <sub>CM</sub> +100 | mV    | V <sub>CM</sub> =1.2V<br>[Note1] |
|                                      | Low                    | V <sub>TL</sub> | V <sub>CM</sub> -100 | -    | -                    | mV    |                                  |
| Input voltage                        | High                   | V <sub>IH</sub> | 2.1                  | -    | -                    | V     | [Note2]                          |
|                                      | Low                    | V <sub>IL</sub> | -                    | -    | 0.8                  |       |                                  |
| Input current                        | High                   | I <sub>OH</sub> | -                    | -    | 400                  | μA    | V <sub>I2</sub> =+3.3V[Note2]    |
|                                      | Low                    | I <sub>OL</sub> | -10.0                | -    | 10.0                 | μA    | V <sub>I2</sub> =0V[Note2]       |
| Input impedance (Differential input) |                        | R <sub>T</sub>  | -                    | 100  | -                    | Ω     |                                  |

[Note1] V<sub>CM</sub> : Common mode voltage of LVDS driver

[Note2]RL/UD,SELLVDS

[Note3]LVDS signals

[Note4]On-off conditions for supply voltage

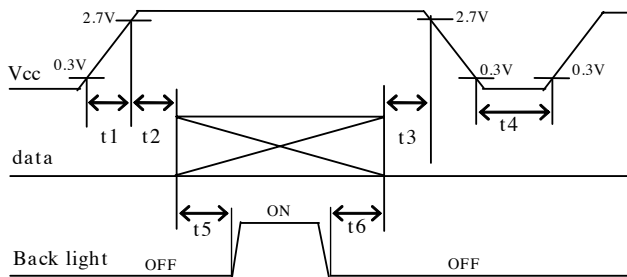

- 0<t1 ≤ 10ms
- 0<t2 ≤ 10ms
- 0<t3 ≤ 1s
- 1s ≤ t4
- 300ms ≤ t5
- 200ms ≤ t6

Vcc-dip conditions

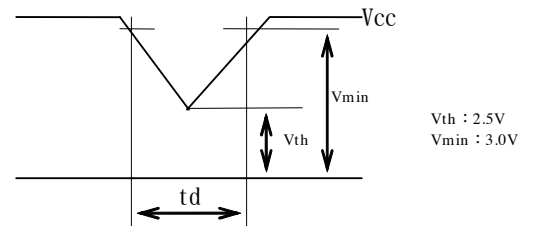

- 1) V<sub>th</sub> ≤ V<sub>CC</sub> < V<sub>min</sub>  
td ≤ 10ms
- 2) V<sub>CC</sub> < V<sub>th</sub>

V<sub>CC</sub>-dip conditions should also follow the On-off conditions for supply voltage

- Please use DE signal by the Lo start.
- Please do not input Vsync/Hsync to this module,it is recommend to be used by the pull-down
- It is recommended to consider some timing difference between LVDS input and Backlight input as shown above.

If the Backlight lights on before LCD starting, or if the Backlight is kept on after LCD stopping, the screen may look white for a moment or abnormal image may be displayed. This is caused by variation in output signal from timing generator at LVDS input on or off. It does not cause the damage to the LCD module

[Note 5] Typical current situation : 253-gray-bar pattern.

(V<sub>CC</sub>=+3.3V,fck=40MHz,Ta=+25°C)

The explanation of each gray scale is described below section 8

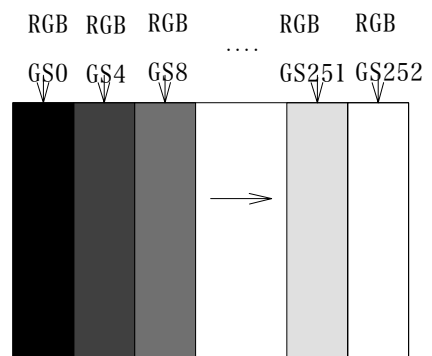

## 6-2. Backlight driving

The backlight system is an edge-lighting type with single CCFT (Cold Cathode Fluorescent Tube).

The characteristics of single lamp are shown in the following table.

| Parameter              | Symbol | Min.                 | Typ. | Max.   | Unit  | Remark   |
|------------------------|--------|----------------------|------|--------|-------|--|
| Lamp current range     | $I_L$  | 3.0                  | 6.0  | 7.0    | mArms | [Note1]  |
| Lamp voltage           | $V_L$  | -                    | 485  | 560    | Vrms  | $T_a=+25^{\circ}\text{C}, I_L=6.0\text{mArms}$ |
| Lamp power consumption | $P_L$  | -                    | 2.9  | -      | W     | [Note2]  |
| Lamp frequency         | $F_L$  | 40                   | -    | 70     | kHz   | [Note3]  |
| Kick-off voltage       | $V_s$  | -                    | -    | 1100   | Vrms  | Inverter output voltage                        |
|                        |        | -                    | -    | (1300) |       | (Trance output voltage)                        |
| Lamp life time         | $L_L$  | 50000<br>(Lump unit) | -    | -      | hour  | $I_L=6.0\text{mA}$ [Note5]                     |
|                        |        | 15000<br>(Module)    | -    | -      |       | [Reference]                                    |

[Note1] Lamp current is measured with current meter for high frequency as shown below.

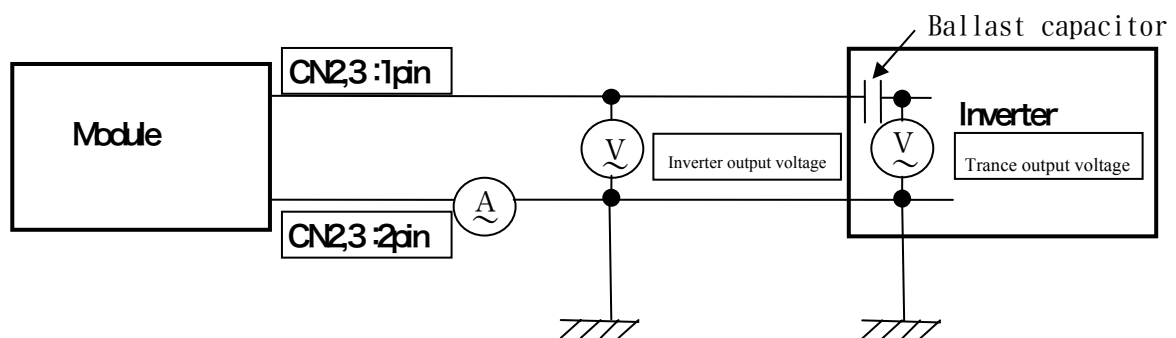

[Note2] Reference value by one fluorescent lamp calculation ( $I_L \times V_L$ )

It is assumed the value that doesn't contain the loss of the inverter. ( $I_L = 6.0\text{mArms}$ )

[Note3] Lamp frequency may produce interference with horizontal synchronous frequency, and this may cause beat on the display. Therefore lamp frequency shall be detached as much as possible from the horizontal synchronous frequency and from the harmonics of horizontal synchronous to avoid interference.

[Note4] The value of the trans output side in the inverter of ballast capacitor 27pF is described. Lighting beginning voltage might rise according to the state of the user cabinet mounting, and please set the open-circuit voltage of the inverter so as not to generate the lighting failure while real used.

The voltage above this value should be applied to the lamp for more than 1 second to start-up. Otherwise the lamp may not be turned on.

[Note5] Since lamp is consumables, the life time written above is referencial value and it is not guaranteed in this specification.

Lamp life time is defined that it applied either ① or ② under this condition  
(Continuous turning on at  $T_a=25^{\circ}\text{C}$ ,  $I_L=6.0\text{mArms}$ )

① Brightness becomes 50% of the original value under standard condition.

② Kick-off voltage at  $T_a=-10^{\circ}\text{C}$  exceeds maximum value, 1500Vrms.

In case of operating under lower temp environment, the lamp exhaustion is accelerated and the brightness becomes lower. (Continuous operating under for around 1 month under lower temp condition may reduce the brightness to half of the original brightness.)

In case of such usage under lower temp environment, periodical lamp exchange is recommended.

[Note] Please synchronize the lighting frequency and the phase of the lamp of the same connector.

There is a possibility to exceed ratings of the connector when not synchronizing.

[Note] The performance of the backlight, for example life time or brightness, is much influenced by the characteristics of the DC-AC inverter for the lamp. When you design or order the inverter, please make sure that a poor lighting caused by the mismatch of the backlight and the inverter (miss-lighting, flicker, etc.) never occur. When you confirm it, the module should be operated in the same condition as it is installed in your instrument.

Be sure to use a back light power supply with the safety protection circuit such as the detection circuit for the excess voltage, excess current and or electric discharge waveform.

Be sure to use the detect circuit by which one side of the CCFT lamps can be controlled independently. Otherwise, when one side of the CCFT is open, the excess current may possibly be applied to the other side of the lamp.

## 7. Timing characteristics of input signals

### 7-1. Timing characteristics

| Parameter              |                          | Symbol  | Min. | Typ. | Max. | Unit    |
|------------------------|--------------------------|---------|------|------|------|---------|
| Clock signal           | Frequency                | $1/T_c$ | 35   | 40   | 42   | MHz     |
|                        | Horizontal period        | TH      | 940  | 1056 | 1395 | clock   |
| ENAB signal            | Horizontal period (High) | THd     | 23.5 | 26.4 | 39.9 | $\mu$ s |
|                        |                          |         | 800  | 800  | 800  | clock   |
|                        | Vertical period          | TV      | 628  | 666  | 698  | line    |
|                        |                          |         | —    | 16.7 | —    | ms      |
| Vertical period (High) | TVd                      | 600     | 600  | 600  | line |         |

[Note] In case of using the long vertical period, the deterioration of display quality, flicker etc. may occur.

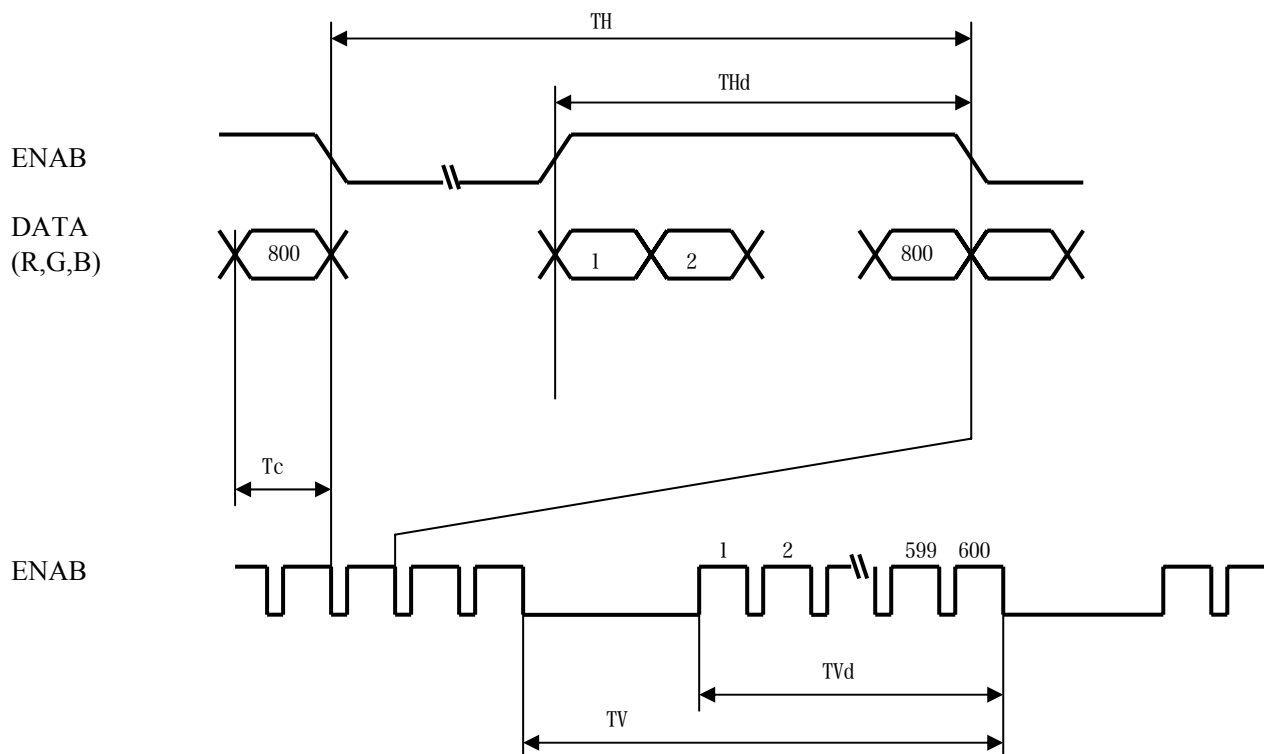

## 7-2. Input Data Signals and Display Position on the screen

Display position of input data  
( H, V )

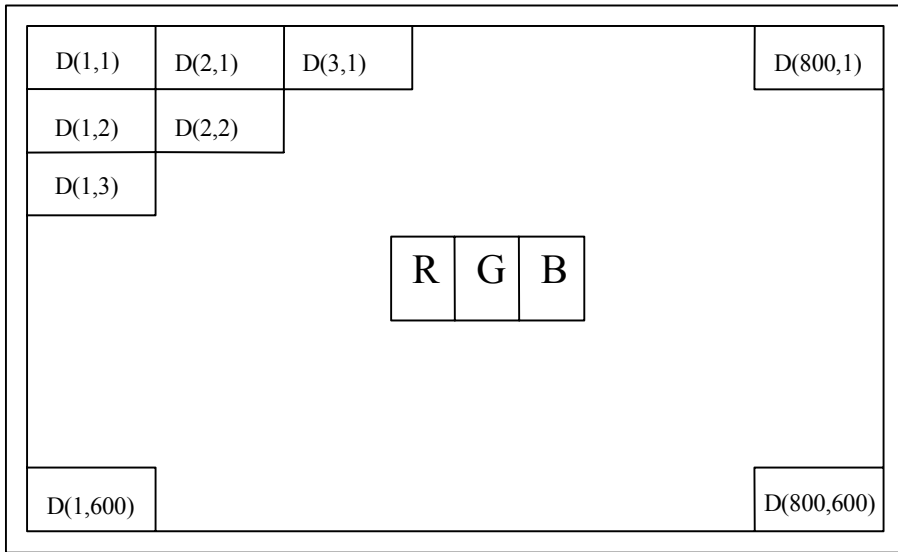

## 8. Input Signals, Basic Display Colors and Gray Scale of Each Color

## 8-1 8bit input

|                     | Colors & Gray scale | Data signal |    |    |    |    |    |    |    |    |    |    |    |    |    |    |    |    |    |    |    |    |    |    |    |    |
|---------------------|---------------------|-------------|----|----|----|----|----|----|----|----|----|----|----|----|----|----|----|----|----|----|----|----|----|----|----|----|
|                     |                     | Gray scale  | R0 | R1 | R2 | R3 | R4 | R5 | R6 | R7 | G0 | G1 | G2 | G3 | G4 | G5 | G6 | G7 | B0 | B1 | B2 | B3 | B4 | B5 | B6 | B7 |
| Basic Color         | Black               | —           | 0  | 0  | 0  | 0  | 0  | 0  | 0  | 0  | 0  | 0  | 0  | 0  | 0  | 0  | 0  | 0  | 0  | 0  | 0  | 0  | 0  | 0  | 0  | 0  |
|                     | Blue                | —           | 0  | 0  | 0  | 0  | 0  | 0  | 0  | 0  | 0  | 0  | 0  | 0  | 0  | 0  | 0  | 0  | X  | X  | 1  | 1  | 1  | 1  | 1  | 1  |
|                     | Green               | —           | 0  | 0  | 0  | 0  | 0  | 0  | 0  | 0  | X  | X  | 1  | 1  | 1  | 1  | 1  | 1  | 0  | 0  | 0  | 0  | 0  | 0  | 0  | 0  |
|                     | Cyan                | —           | 0  | 0  | 0  | 0  | 0  | 0  | 0  | 0  | X  | X  | 1  | 1  | 1  | 1  | 1  | 1  | X  | X  | 1  | 1  | 1  | 1  | 1  | 1  |
|                     | Red                 | —           | X  | X  | 1  | 1  | 1  | 1  | 1  | 1  | 0  | 0  | 0  | 0  | 0  | 0  | 0  | 0  | 0  | 0  | 0  | 0  | 0  | 0  | 0  | 0  |
|                     | Magenta             | —           | X  | X  | 1  | 1  | 1  | 1  | 1  | 1  | 0  | 0  | 0  | 0  | 0  | 0  | 0  | 0  | X  | X  | 1  | 1  | 1  | 1  | 1  | 1  |
|                     | Yellow              | —           | X  | X  | 1  | 1  | 1  | 1  | 1  | 1  | X  | X  | 1  | 1  | 1  | 1  | 1  | 1  | 0  | 0  | 0  | 0  | 0  | 0  | 0  | 0  |
|                     | White               | —           | X  | X  | 1  | 1  | 1  | 1  | 1  | 1  | X  | X  | 1  | 1  | 1  | 1  | 1  | 1  | X  | X  | 1  | 1  | 1  | 1  | 1  | 1  |
| Gray Scale of Red   | Black               | GS0         | 0  | 0  | 0  | 0  | 0  | 0  | 0  | 0  | 0  | 0  | 0  | 0  | 0  | 0  | 0  | 0  | 0  | 0  | 0  | 0  | 0  | 0  | 0  | 0  |
|                     | ↑                   | GS1         | 1  | 0  | 0  | 0  | 0  | 0  | 0  | 0  | 0  | 0  | 0  | 0  | 0  | 0  | 0  | 0  | 0  | 0  | 0  | 0  | 0  | 0  | 0  | 0  |
|                     | Darker              | GS2         | 0  | 1  | 0  | 0  | 0  | 0  | 0  | 0  | 0  | 0  | 0  | 0  | 0  | 0  | 0  | 0  | 0  | 0  | 0  | 0  | 0  | 0  | 0  | 0  |
|                     | ↑                   | ↓           |    |    |    |    | ↓  |    |    |    |    |    |    | ↓  |    |    |    |    |    |    |    | ↓  |    |    |    |    |
|                     | ↓                   | ↓           |    |    |    |    | ↓  |    |    |    |    |    |    | ↓  |    |    |    |    |    |    |    | ↓  |    |    |    |    |
|                     | Brighter            | GS250       | 1  | 0  | 0  | 1  | 1  | 1  | 1  | 1  | 0  | 0  | 0  | 0  | 0  | 0  | 0  | 0  | 0  | 0  | 0  | 0  | 0  | 0  | 0  | 0  |
|                     | ↓                   | GS251       | 1  | 1  | 0  | 1  | 1  | 1  | 1  | 1  | 0  | 0  | 0  | 0  | 0  | 0  | 0  | 0  | 0  | 0  | 0  | 0  | 0  | 0  | 0  | 0  |
|                     | Red                 | GS252       | X  | X  | 1  | 1  | 1  | 1  | 1  | 1  | 0  | 0  | 0  | 0  | 0  | 0  | 0  | 0  | 0  | 0  | 0  | 0  | 0  | 0  | 0  | 0  |
| Gray Scale of Green | Black               | GS0         | 0  | 0  | 0  | 0  | 0  | 0  | 0  | 0  | 0  | 0  | 0  | 0  | 0  | 0  | 0  | 0  | 0  | 0  | 0  | 0  | 0  | 0  | 0  | 0  |
|                     | ↑                   | GS1         | 0  | 0  | 0  | 0  | 0  | 0  | 0  | 0  | 1  | 0  | 0  | 0  | 0  | 0  | 0  | 0  | 0  | 0  | 0  | 0  | 0  | 0  | 0  | 0  |
|                     | Darker              | GS2         | 0  | 0  | 0  | 0  | 0  | 0  | 0  | 0  | 0  | 1  | 0  | 0  | 0  | 0  | 0  | 0  | 0  | 0  | 0  | 0  | 0  | 0  | 0  | 0  |
|                     | ↑                   | ↓           |    |    |    |    | ↓  |    |    |    |    |    |    | ↓  |    |    |    |    |    |    |    | ↓  |    |    |    |    |
|                     | ↓                   | ↓           |    |    |    |    | ↓  |    |    |    |    |    |    | ↓  |    |    |    |    |    |    |    | ↓  |    |    |    |    |
|                     | Brighter            | GS250       | 0  | 0  | 0  | 0  | 0  | 0  | 0  | 0  | 1  | 0  | 0  | 1  | 1  | 1  | 1  | 1  | 0  | 0  | 0  | 0  | 0  | 0  | 0  | 0  |
|                     | ↓                   | GS251       | 0  | 0  | 0  | 0  | 0  | 0  | 0  | 0  | 1  | 1  | 0  | 1  | 1  | 1  | 1  | 1  | 0  | 0  | 0  | 0  | 0  | 0  | 0  | 0  |
|                     | Green               | GS252       | 0  | 0  | 0  | 0  | 0  | 0  | 0  | 0  | X  | X  | 1  | 1  | 1  | 1  | 1  | 1  | 0  | 0  | 0  | 0  | 0  | 0  | 0  | 0  |
| Gray Scale of Blue  | Black               | GS0         | 0  | 0  | 0  | 0  | 0  | 0  | 0  | 0  | 0  | 0  | 0  | 0  | 0  | 0  | 0  | 0  | 0  | 0  | 0  | 0  | 0  | 0  | 0  | 0  |
|                     | ↑                   | GS1         | 0  | 0  | 0  | 0  | 0  | 0  | 0  | 0  | 0  | 0  | 0  | 0  | 0  | 0  | 0  | 0  | 1  | 0  | 0  | 0  | 0  | 0  | 0  | 0  |
|                     | Darker              | GS2         | 0  | 0  | 0  | 0  | 0  | 0  | 0  | 0  | 0  | 0  | 0  | 0  | 0  | 0  | 0  | 0  | 0  | 1  | 0  | 0  | 0  | 0  | 0  | 0  |
|                     | ↑                   | ↓           |    |    |    |    | ↓  |    |    |    |    |    |    | ↓  |    |    |    |    |    |    |    | ↓  |    |    |    |    |
|                     | ↓                   | ↓           |    |    |    |    | ↓  |    |    |    |    |    |    | ↓  |    |    |    |    |    |    |    | ↓  |    |    |    |    |
|                     | Brighter            | GS250       | 0  | 0  | 0  | 0  | 0  | 0  | 0  | 0  | 0  | 0  | 0  | 0  | 0  | 0  | 0  | 0  | 1  | 0  | 0  | 1  | 1  | 1  | 1  | 1  |
|                     | ↓                   | GS251       | 0  | 0  | 0  | 0  | 0  | 0  | 0  | 0  | 0  | 0  | 0  | 0  | 0  | 0  | 0  | 0  | 1  | 1  | 0  | 1  | 1  | 1  | 1  | 1  |
|                     | Blue                | GS252       | 0  | 0  | 0  | 0  | 0  | 0  | 0  | 0  | 0  | 0  | 0  | 0  | 0  | 0  | 0  | 0  | X  | X  | 1  | 1  | 1  | 1  | 1  | 1  |

0 : Low level voltage, 1 : High level voltage x : Don't care

Red color can be displayed in 228 gray scales from 8 bit data signals.

Green color can be displayed in 253 gray scales from 8 bit data signals.

Blue color can be displayed in 253 gray scales from 8 bit data signals.

According to the combination of each color, about 12-million-color display can be achieved on the screen.

Please refer to **【Appendix A】** of the end for the output Gray scale of each basic color.

## 8-2 6bit input

|                     | Colors &<br>Gray scale | Data signal   |    |    |    |    |    |    |    |    |    |    |    |    |    |    |    |    |    |    |
|---------------------|------------------------|---------------|----|----|----|----|----|----|----|----|----|----|----|----|----|----|----|----|----|----|
|                     |                        | Gray<br>scale | R0 | R1 | R2 | R3 | R4 | R5 | G0 | G1 | G2 | G3 | G4 | G5 | B0 | B1 | B2 | B3 | B4 | B5 |
| Basic Color         | —                      | —             | 0  | 0  | 0  | 0  | 0  | 0  | 0  | 0  | 0  | 0  | 0  | 0  | 0  | 0  | 0  | 0  | 0  | 0  |
|                     | Black                  | —             | 0  | 0  | 0  | 0  | 0  | 0  | 0  | 0  | 0  | 0  | 0  | 0  | 1  | 1  | 1  | 1  | 1  | 1  |
|                     | Blue                   | —             | 0  | 0  | 0  | 0  | 0  | 0  | 1  | 1  | 1  | 1  | 1  | 1  | 0  | 0  | 0  | 0  | 0  | 0  |
|                     | Green                  | —             | 0  | 0  | 0  | 0  | 0  | 0  | 1  | 1  | 1  | 1  | 1  | 1  | 1  | 1  | 1  | 1  | 1  | 1  |
|                     | Cyan                   | —             | 1  | 1  | 1  | 1  | 1  | 1  | 0  | 0  | 0  | 0  | 0  | 0  | 0  | 0  | 0  | 0  | 0  | 0  |
|                     | Red                    | —             | 1  | 1  | 1  | 1  | 1  | 1  | 0  | 0  | 0  | 0  | 0  | 0  | 1  | 1  | 1  | 1  | 1  | 1  |
|                     | Magenta                | —             | 1  | 1  | 1  | 1  | 1  | 1  | 1  | 1  | 1  | 1  | 1  | 1  | 0  | 0  | 0  | 0  | 0  | 0  |
|                     | Yellow                 | —             | 1  | 1  | 1  | 1  | 1  | 1  | 1  | 1  | 1  | 1  | 1  | 1  | 1  | 1  | 1  | 1  | 1  | 1  |
| Gray Scale of Red   | White                  | GS0           | 0  | 0  | 0  | 0  | 0  | 0  | 0  | 0  | 0  | 0  | 0  | 0  | 0  | 0  | 0  | 0  | 0  | 0  |
|                     | Black                  | GS1           | 1  | 0  | 0  | 0  | 0  | 0  | 0  | 0  | 0  | 0  | 0  | 0  | 0  | 0  | 0  | 0  | 0  | 0  |
|                     | ↑                      | GS2           | 0  | 1  | 0  | 0  | 0  | 0  | 0  | 0  | 0  | 0  | 0  | 0  | 0  | 0  | 0  | 0  | 0  | 0  |
|                     | Darker                 | ↓             |    |    |    | ↓  |    |    |    |    | ↓  |    |    |    |    |    | ↓  |    |    |    |
|                     | ↑                      | ↓             |    |    |    | ↓  |    |    |    |    | ↓  |    |    |    |    |    | ↓  |    |    |    |
|                     | ↓                      | GS61          | 1  | 0  | 1  | 1  | 1  | 1  | 0  | 0  | 0  | 0  | 0  | 0  | 0  | 0  | 0  | 0  | 0  | 0  |
|                     | Brighter               | GS62          | 0  | 1  | 1  | 1  | 1  | 1  | 0  | 0  | 0  | 0  | 0  | 0  | 0  | 0  | 0  | 0  | 0  | 0  |
|                     | ↓                      | GS63          | 1  | 1  | 1  | 1  | 1  | 1  | 0  | 0  | 0  | 0  | 0  | 0  | 0  | 0  | 0  | 0  | 0  | 0  |
| Gray Scale of Green | Red                    | GS0           | 0  | 0  | 0  | 0  | 0  | 0  | 0  | 0  | 0  | 0  | 0  | 0  | 0  | 0  | 0  | 0  | 0  | 0  |
|                     | Black                  | GS1           | 0  | 0  | 0  | 0  | 0  | 0  | 1  | 0  | 0  | 0  | 0  | 0  | 0  | 0  | 0  | 0  | 0  | 0  |
|                     | ↑                      | GS2           | 0  | 0  | 0  | 0  | 0  | 0  | 0  | 1  | 0  | 0  | 0  | 0  | 0  | 0  | 0  | 0  | 0  | 0  |
|                     | Darker                 | ↓             |    |    |    | ↓  |    |    |    |    | ↓  |    |    |    |    |    | ↓  |    |    |    |
|                     | ↑                      | ↓             |    |    |    | ↓  |    |    |    |    | ↓  |    |    |    |    |    | ↓  |    |    |    |
|                     | ↓                      | GS61          | 0  | 0  | 0  | 0  | 0  | 0  | 1  | 0  | 1  | 1  | 1  | 1  | 0  | 0  | 0  | 0  | 0  | 0  |
|                     | Brighter               | GS62          | 0  | 0  | 0  | 0  | 0  | 0  | 0  | 1  | 1  | 1  | 1  | 1  | 0  | 0  | 0  | 0  | 0  | 0  |
|                     | ↓                      | GS63          | 0  | 0  | 0  | 0  | 0  | 0  | 1  | 1  | 1  | 1  | 1  | 1  | 0  | 0  | 0  | 0  | 0  | 0  |
| Gray Scale of Blue  | Green                  | GS0           | 0  | 0  | 0  | 0  | 0  | 0  | 0  | 0  | 0  | 0  | 0  | 0  | 0  | 0  | 0  | 0  | 0  | 0  |
|                     | Black                  | GS1           | 0  | 0  | 0  | 0  | 0  | 0  | 0  | 0  | 0  | 0  | 0  | 0  | 1  | 0  | 0  | 0  | 0  | 0  |
|                     | ↑                      | GS2           | 0  | 0  | 0  | 0  | 0  | 0  | 0  | 0  | 0  | 0  | 0  | 0  | 0  | 1  | 0  | 0  | 0  | 0  |
|                     | Darker                 | ↓             |    |    |    | ↓  |    |    |    |    | ↓  |    |    |    |    |    | ↓  |    |    |    |
|                     | ↑                      | ↓             |    |    |    | ↓  |    |    |    |    | ↓  |    |    |    |    |    | ↓  |    |    |    |
|                     | ↓                      | GS61          | 0  | 0  | 0  | 0  | 0  | 0  | 0  | 0  | 0  | 0  | 0  | 0  | 1  | 0  | 1  | 1  | 1  | 1  |
|                     | Brighter               | GS62          | 0  | 0  | 0  | 0  | 0  | 0  | 0  | 0  | 0  | 0  | 0  | 0  | 0  | 1  | 1  | 1  | 1  | 1  |
|                     | ↓                      | GS63          | 0  | 0  | 0  | 0  | 0  | 0  | 0  | 0  | 0  | 0  | 0  | 0  | 1  | 1  | 1  | 1  | 1  | 1  |

0 : Low level voltage,            1 : High level voltage.

Each basic color can be displayed in 64 gray scales from 6 bit data signals. According to the combination of total 18 bit data signals, the 262,144-color display can be achieved on the screen.



## 9. Optical Characteristics

Ta=+25°C, Vcc =+3.3V

| Parameter             |                 | Symbol                 | Condition             | Min.  | Typ.  | Max.  | Unit | Remark                   |                   |   |
|-----------------------|-----------------|------------------------|-----------------------|-------|-------|-------|------|--------------------------|-------------------|---|
| Viewing angle range   | Horizontal      | $\theta 21, \theta 22$ | $CR \geq 10$          | 60    | 70    | -     | Deg. |                          |                   |   |
|                       | Vertical        | $\theta 11$            |                       | 35    | 50    | -     | Deg. |                          |                   |   |
|                       |                 | $\theta 12$            |                       | 55    | 60    | -     | Deg. |                          |                   |   |
| Contrast ratio        |                 | C R                    | Optimum viewing angle | 250   | 450   | -     | -    | [Note2,4]                |                   |   |
| Response time         | gray scale      | $\tau$                 | $\theta = 0^\circ$    | -     | 10    | -     | ms   | [Note3(Condition 1),4,5] |                   |   |
|                       | black and white | $\tau_d + \tau_r$      |                       | -     | 35    | -     | ms   | [Note3(Condition 2),4,5] |                   |   |
| Chromaticity of White |                 | x                      | $\theta = 0^\circ$    | 0.283 | 0.313 | 0.343 | -    | [Note4]                  |                   |   |
|                       |                 | y                      |                       | 0.299 | 0.329 | 0.359 | -    |                          |                   |   |
| Chromaticity of Red   |                 | x                      |                       | 0.618 | 0.648 | 0.678 | -    |                          |                   |   |
|                       |                 | y                      |                       | 0.306 | 0.336 | 0.366 | -    |                          |                   |   |
| Chromaticity of Green |                 | x                      |                       | 0.253 | 0.283 | 0.313 | -    |                          |                   |   |
|                       |                 | y                      |                       | 0.582 | 0.612 | 0.642 | -    |                          |                   |   |
| Chromaticity of Blue  |                 | x                      |                       | 0.114 | 0.144 | 0.174 | -    |                          |                   |   |
|                       |                 | y                      |                       | 0.052 | 0.082 | 0.112 | -    |                          |                   |   |
| Luminance of white    |                 | YL                     |                       |       | 260   | 330   | -    |                          | cd/m <sup>2</sup> | [Note4]<br>F = 60KHz<br>I <sub>L</sub> = 6.0mArms |
| White Uniformity      |                 | $\delta w$             |                       |       | -     | -     | 1.25 |                          | -                 | [Note5]   |

※ The measurement shall be executed 30 minutes after lighting at rating.

The optical characteristics shall be measured in a dark room or equivalent state with the method shown in Fig.2 below.

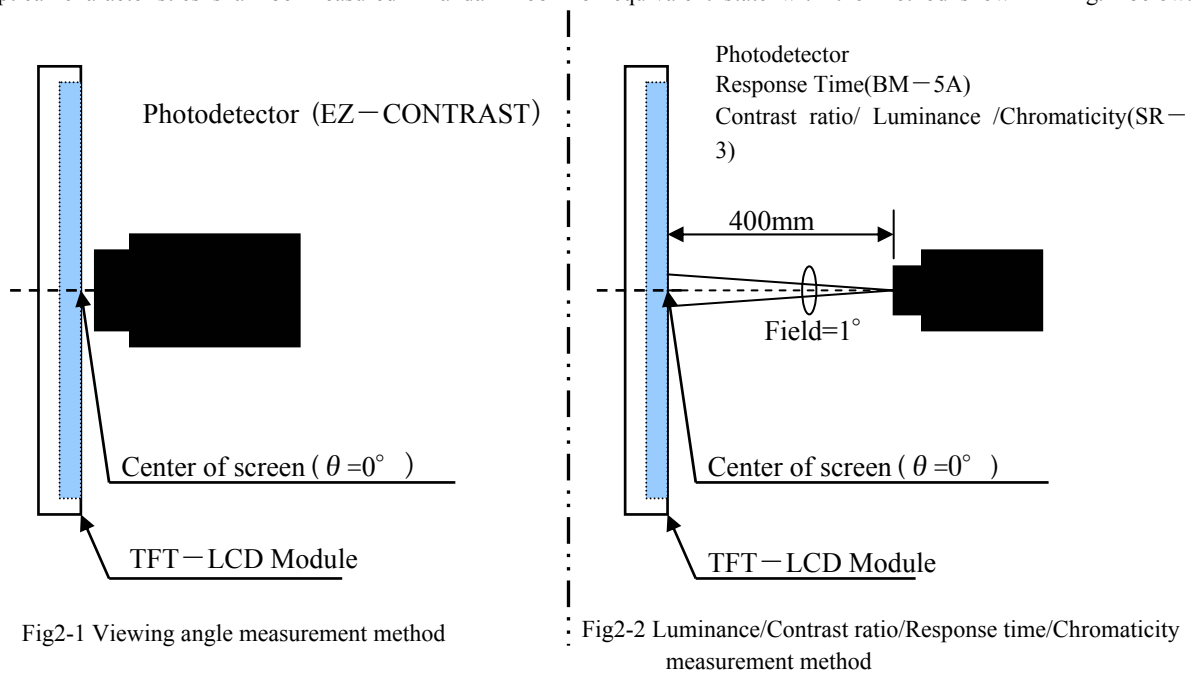
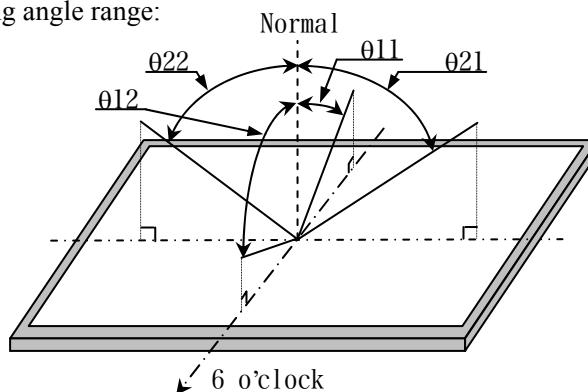

Fig2 Optical characteristics measurement method

[Note1]Definitions of viewing angle range:



[Note2]Definition of contrast ratio:

The contrast ratio is defined as the following.

$$\text{Contrast Ratio (CR)} = \frac{\text{Luminance (brightness) with all pixels white}}{\text{Luminance (brightness) with all pixels black}}$$

[Note3] Definition of response time:

<Condition 1 : > Definition by gray scal

The response time is defined as the following figure and shall be measured by switching the input signal for nine kinds of gray scales (GS0,32,64,96,128,160,192,224,255) and nine kinds of scales gray signal. (GS0,32,64,96,128,160,192, 224,255)

(Panel surface temperature : 40°C)

|       | GS0           | GS32           | GS64           | GS96           | GS128           | GS160           | GS192           | GS224           | GS255           |
|-------|---------------|----------------|----------------|----------------|-----------------|-----------------|-----------------|-----------------|-----------------|
| GS0   |               | $\tau r0-32$   | $\tau r0-64$   | $\tau r0-96$   | $\tau r0-128$   | $\tau r0-160$   | $\tau r0-192$   | $\tau r0-224$   | $\tau r0-255$   |
| GS32  | $\tau d32-0$  |                | $\tau r32-64$  | $\tau r32-96$  | $\tau r32-128$  | $\tau r32-160$  | $\tau r32-192$  | $\tau r32-224$  | $\tau r32-255$  |
| GS64  | $\tau d64-0$  | $\tau d64-32$  |                | $\tau r64-96$  | $\tau r64-128$  | $\tau r64-160$  | $\tau r64-192$  | $\tau r64-224$  | $\tau r64-255$  |
| GS96  | $\tau d96-0$  | $\tau d96-32$  | $\tau d96-64$  |                | $\tau r96-128$  | $\tau r96-160$  | $\tau r96-192$  | $\tau r96-224$  | $\tau r96-255$  |
| GS128 | $\tau d128-0$ | $\tau d128-32$ | $\tau d128-64$ | $\tau d128-96$ |                 | $\tau r128-160$ | $\tau r128-192$ | $\tau r128-224$ | $\tau r128-255$ |
| GS160 | $\tau d160-0$ | $\tau d160-32$ | $\tau d160-64$ | $\tau d160-96$ | $\tau d160-128$ |                 | $\tau r160-192$ | $\tau r160-224$ | $\tau r160-255$ |
| GS192 | $\tau d192-0$ | $\tau d192-32$ | $\tau d196-64$ | $\tau d196-96$ | $\tau d196-128$ | $\tau d196-160$ |                 | $\tau r192-224$ | $\tau r192-255$ |
| GS224 | $\tau d224-0$ | $\tau d224-32$ | $\tau d224-64$ | $\tau d224-96$ | $\tau d224-128$ | $\tau d224-160$ | $\tau d224-192$ |                 | $\tau r224-255$ |
| GS255 | $\tau d255-0$ | $\tau d255-32$ | $\tau d255-64$ | $\tau d255-96$ | $\tau d255-128$ | $\tau d255-160$ | $\tau d255-192$ | $\tau d255-224$ |                 |

$\tau^*:x-y...$  Switching time from a option gray scale (x) to other option gray scale (y)

$$\tau = \{ \sum (\tau r:x-y) + \sum (\tau d:x-y) \} / 72$$

<Condition 2 : > Definition by black and white

The response time is defined as the following figure and shall be measured by switching the input signal for "black" and "white".

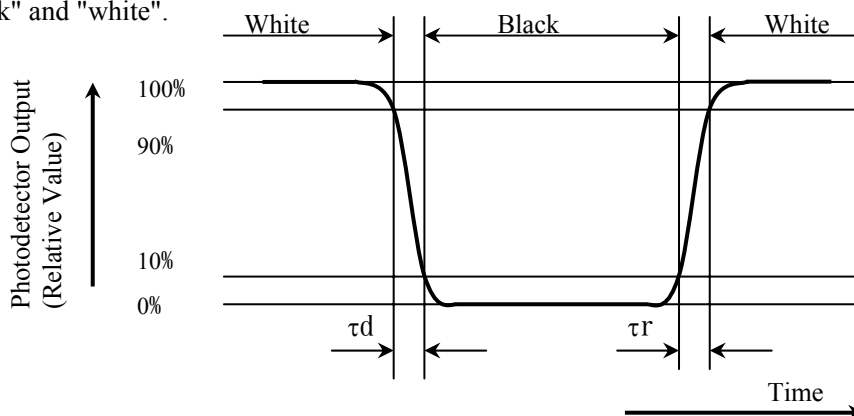

[Note4] This shall be measured at center of the screen.

[Note5] Definition of white uniformity:

White uniformity is defined as the following with five measurements(A~E).

$$\delta w = \frac{\text{Maximum Luminance of five points (brightness)}}{\text{Minimum Luminance of five points (brightness)}}$$

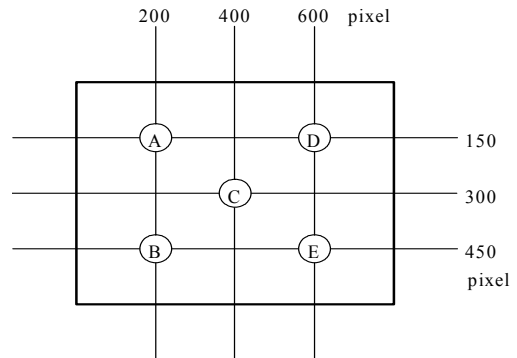

## 10. Display Quality

The display quality of the color TFT-LCD module shall be in compliance with the Incoming Inspection Standard.

## 11. Handling Precautions

- a) Be sure to turn off the power supply when inserting or disconnecting the cable.
- b) Be sure to design the cabinet so that the module can be installed without any extra stress such as warp or twist.
- c) Since the front polarizer is easily damaged, pay attention not to scratch it.
- d) Wipe off water drop immediately. Long contact with water may cause discoloration or spots.
- e) When the panel surface is soiled, wipe it with absorbent cotton or other soft cloth.
- f) Since the panel is made of glass, it may break or crack if dropped or bumped on hard surface. Handle with care.
- g) Since CMOS LSI is used in this module, take care of static electricity and injure the human earth when handling. Observe all other precautionary requirements in handling components.
- h) Since there is a circuit board in the module back, stress is not added at the time of a design assembly. Please make it like. If stress is added, there is a possibility that circuit parts may be damaged.
- i) Protection film is attached to the module surface to prevent it from being scratched . Peel the film off slowly , just before the use, with strict attention to electrostatic charges. Blow off 'dust' on the polarizer by using an ionized nitrogen.
- j) The polarizer surface on the panel is treated with Anti-Glare for low reflection. In case of attaching protective board over the LCD, be careful about the optical interface fringe etc. which degrades display quality.
- k) Do not expose the LCD panel to direct sunlight. Lightproof shade etc. should be attached when LCD panel is used under such environmentl
- l) Connect GND to 4 place of mounting holes to stabilize against EMI and external noise.
- m) There are high voltage portions on the backlight and very dangerous. Careless touch may lead to electrical shock. When exchange lamps or service, turn off the power without tail.
- n) When handling LCD modules and assembling them into cabinets, please be noted that long-term storage in the environment of oxidization or deoxidization gas and the use of such materials as reagent,solvent, adhesive, resin, etc. which generate these gasses, may cause corrosion and discoloration of the LCD modules.
- o) Cold cathode fluorescent lamp in LCD panel contains a small amount of mercury, please follow local ordinances or regulations for disposal.
- p) Be careful of a back light lead not to pull by force at the time of the wiring to an inverter, or line processing.
- q) When install LCD modules in the cabinet, please tighten with “torque=0.294±0.02N·m(3.0±0.2kgf·cm)”.

## 12. Packing form

|   |                             |
|---|-----------------------------|
| Piling number of cartons                          | MAX. 5                      |
| Package quantity in one carton                    | 10pcs                       |
| Carton size                                       | 395(W) × 275(H) × 350(D) mm |
| Total mass of one carton filled with full modules | 8000g                       |
| Packing form is shown                             | Fig.3                       |

## 13. Reliability test items

| No. | Test item                                       | Conditions   | Remark |
|-----|---|--|--------|
| 1   | High temperature storage test                   | Ta=75°C 240h   |        |
| 2   | Low temperature storage test                    | Ta= -30°C 240h   |        |
| 3   | High temperature & high humidity operation test | Ta=40°C ; 95%RH 240h<br>(No condensation)  |        |
| 4   | High temperature operation test                 | T=75°C (panel surface) 240h  |        |
| 5   | Low temperature operation test                  | Ta= -10°C 240h   |        |
| 6   | Vibration test<br>(non- operating)              | Frequency: 10~57Hz/Vibration width (one side):0.075mm<br>: 58~500Hz/Gravity:9.8m/s <sup>2</sup><br>Sweep time : 11 minutes<br>Test period : 3 hours (1 hour for each direction of X,Y,Z) |        |
| 7   | Shock test<br>(non- operating)                  | Max. gravity : 490m/s <sup>2</sup><br>Pulse width : 11ms, half sine wave<br>Direction : ±X, ±Y, ±Z once for each direction.  |        |
| 8   | ESD test  | Contact discharge (150pF 330Ω)<br>non-operating = ±10kV, operating = ±8kV<br>Atmospheric discharge (150pF 330Ω)<br>non-operating = ±20kV, operating = ±15kV                              |        |

## [Result Evaluation Criteria]

Under the display quality test conditions with normal operation state, these shall be no change which may affect practical display function. (normal operation state : Temperature:15~35°C, Humidity:45~75%, Atmospheric pressure:86~106kpa)

## 14.Others

## 1) Lot number Label:

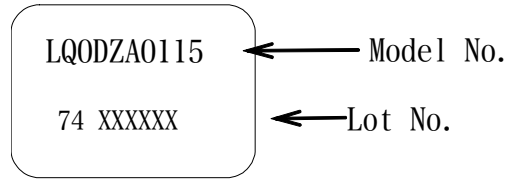

- 2) Adjusting volume have been set optimally before shipment, so do not change any adjusted value.  
If adjusted value is changed, the specification may not be satisfied.
- 3) Disassembling the module can cause permanent damage and should be strictly avoided.
- 4) Please be careful since image retention may occur when a fixed pattern is displayed for a long time.

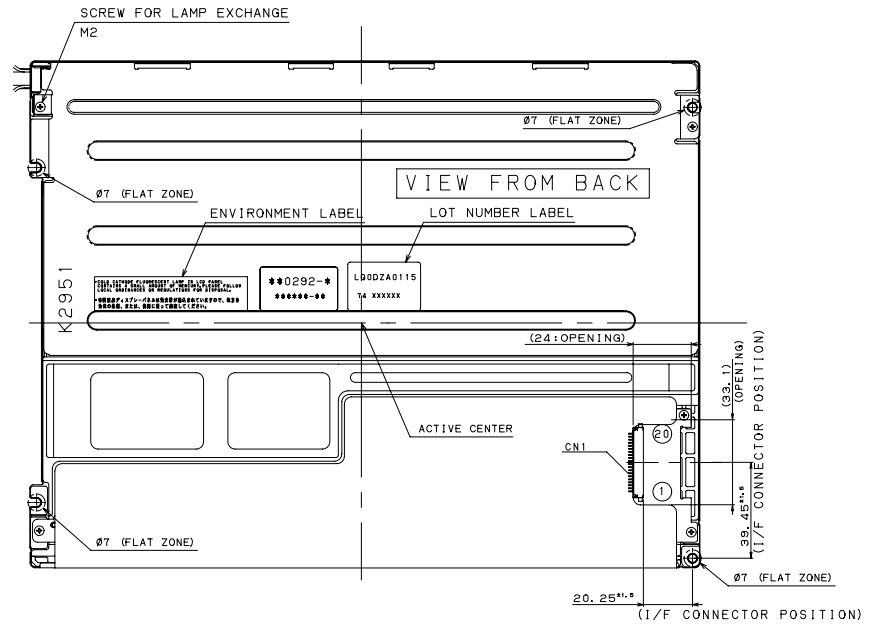
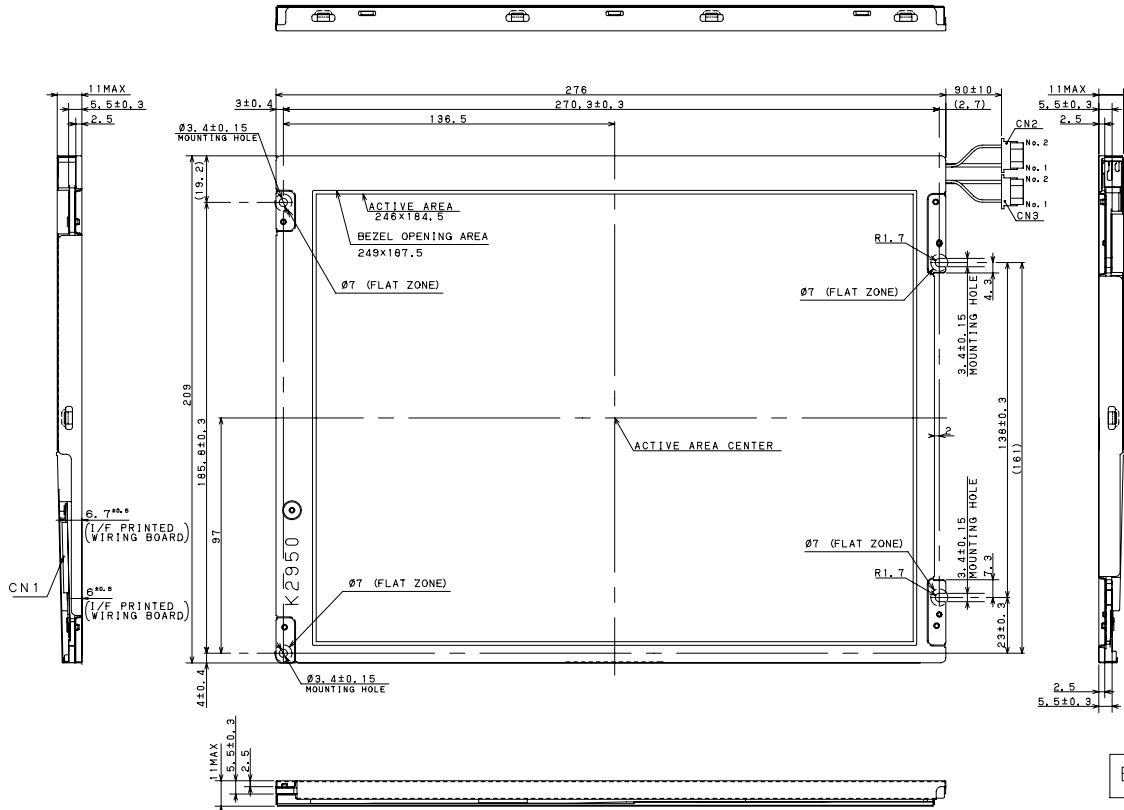

INTERFACE CONNECTOR  
CN1:PIN LAYOUT

| pin    | 1      | 2      | 3      | 4       | 5      | 6      | 7      |
|--------|--------|--------|--------|---------|--------|--------|--------|
|        | VCC    | VCC    | GND    | GND     | RxIN0- | RxIN0+ | GND    |
| 8      | 9      | 10     | 11     | 12      | 13     | 14     | 15     |
| RxIN1- | RxIN1+ | GND    | RxIN2- | RxIN2+  | GND    | CK IN- | CK IN+ |
| 16     | 17     | 18     | 19     | 20      |        |        |        |
| GND    | RxIN3- | RxIN3+ | RL/UD  | SELLVDS |        |        |        |

CORRESPONDING CONNECTOR: [DF14-20S-1.25C (CONNECTOR) (HIROSE ELECTRIC)]  
[DF14-2628SCF (TERMINAL) (HIROSE ELECTRIC)]

BEZEL/DISPLAY POSITION

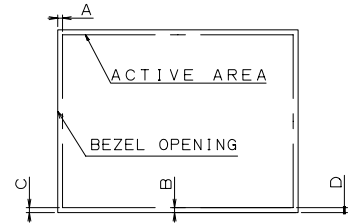

- 1) TOLERANCE X-DIRECTION A: 1.5±0.8
- 2) TOLERANCE Y-DIRECTION B: 1.5±0.8
- 3) OBLIQUITY OF DISPLAY AREA IC-DI<0.8

CCFT CONNECTOR (JST)  
CN2, CN3:  
[BHR-02 (8.0) VS-1N]

| PIN LAYOUT | WIRE COLOR  |       |
|------------|-------------|-------|
|            | CN2         | CN3   |
| 1          | VHIGH WHITE | PINK  |
| 2          | VLOW GRAY   | WHITE |

- NOTES
- 1) UNSPECIFIED TOLERANCE TO BE ±0.5
  - 2) WARP AND FLATING FOR PCB AND CHASSIS ARE EXCLUDED FROM THICKNESS AND DIMENSION OF THE UNIT.
  - 3) RECOMMENDED TIGHTEN TORQUE FOR MOUNTING  
0.294±0.02N·m  
(3.0±0.2kgf·cm)

Fig1:OUTLINE DEMENSIONS

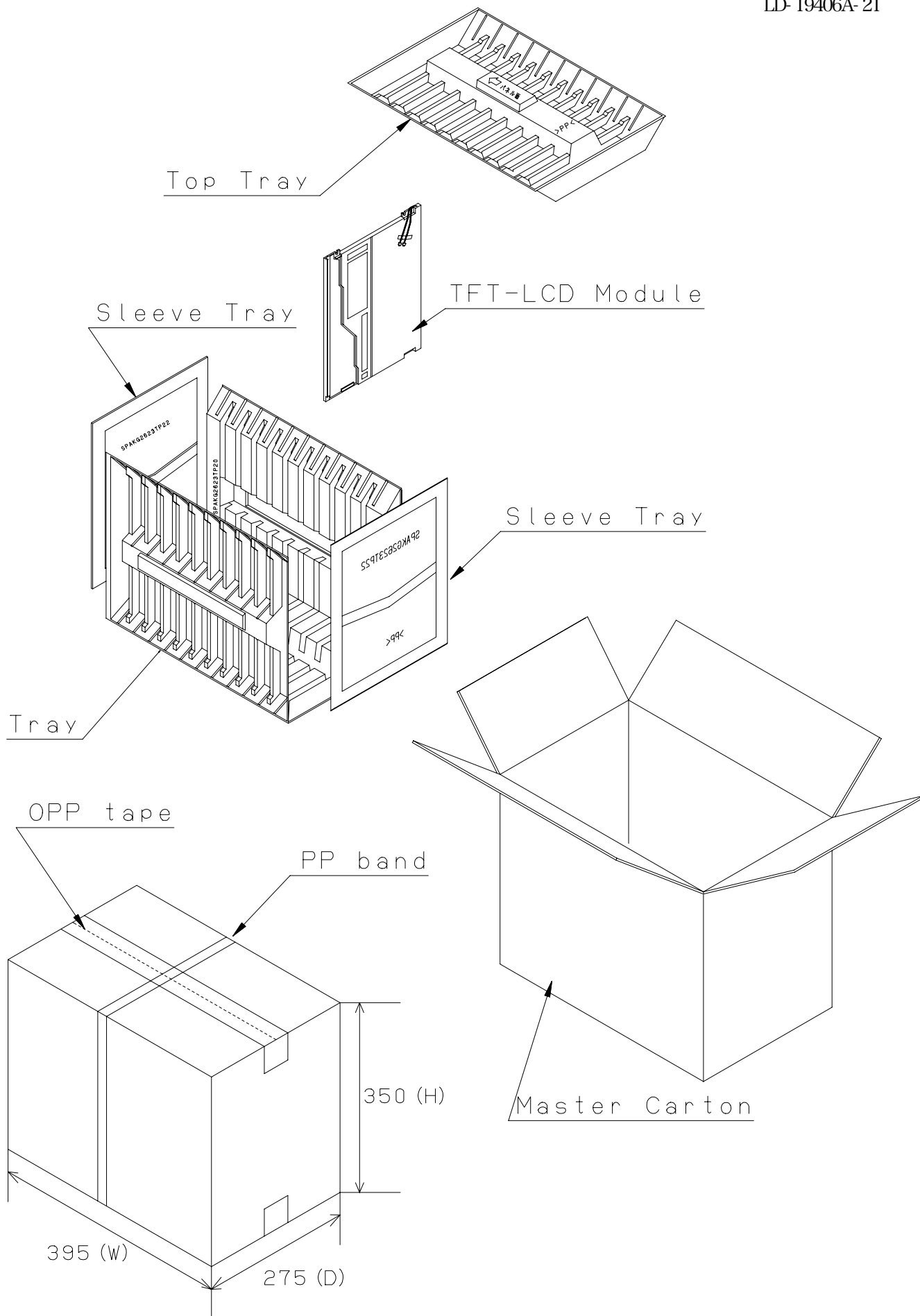

Fig 3 : Packing Form

**Appendix A)**

Output Gray scale table to input data of each basic color (R,G,B)

|                      | R   | G   | B   |
|----------------------|-----|-----|-----|
| Number of Gray scale | 228 | 232 | 225 |

| Input Gray scale | Output Gray scale |    |    |
|------------------|-------------------|----|----|
|                  | R                 | G  | B  |
| GS0              | 0                 | 0  | 0  |
| GS1              | 0                 | 0  | 0  |
| GS2              | 1                 | 1  | 1  |
| GS3              | 2                 | 2  | 2  |
| GS4              | 3                 | 3  | 2  |
| GS5              | 4                 | 4  | 3  |
| GS6              | 5                 | 4  | 3  |
| GS7              | 5                 | 5  | 4  |
| GS8              | 6                 | 6  | 5  |
| GS9              | 7                 | 7  | 5  |
| GS10             | 8                 | 7  | 6  |
| GS11             | 9                 | 8  | 7  |
| GS12             | 9                 | 9  | 7  |
| GS13             | 10                | 10 | 8  |
| GS14             | 11                | 11 | 8  |
| GS15             | 12                | 11 | 9  |
| GS16             | 13                | 12 | 10 |
| GS17             | 14                | 13 | 10 |
| GS18             | 14                | 14 | 11 |
| GS19             | 15                | 15 | 12 |
| GS20             | 16                | 15 | 12 |
| GS21             | 17                | 16 | 13 |
| GS22             | 18                | 17 | 13 |
| GS23             | 18                | 18 | 14 |
| GS24             | 19                | 18 | 15 |
| GS25             | 20                | 19 | 15 |
| GS26             | 21                | 20 | 16 |
| GS27             | 22                | 21 | 17 |
| GS28             | 22                | 22 | 17 |
| GS29             | 23                | 22 | 18 |
| GS30             | 24                | 23 | 18 |
| GS31             | 25                | 24 | 19 |
| GS32             | 26                | 25 | 20 |
| GS33             | 27                | 26 | 20 |
| GS34             | 27                | 26 | 21 |
| GS35             | 28                | 27 | 22 |
| GS36             | 29                | 28 | 22 |
| GS37             | 30                | 29 | 23 |
| GS38             | 31                | 29 | 24 |
| GS39             | 31                | 30 | 24 |
| GS40             | 32                | 31 | 25 |
| GS41             | 33                | 32 | 25 |
| GS42             | 34                | 33 | 26 |
| GS43             | 35                | 33 | 27 |
| GS44             | 36                | 34 | 27 |
| GS45             | 36                | 35 | 28 |
| GS46             | 37                | 36 | 29 |
| GS47             | 38                | 37 | 29 |
| GS48             | 39                | 37 | 30 |
| GS49             | 40                | 38 | 30 |
| GS50             | 40                | 39 | 31 |
| GS51             | 41                | 40 | 32 |
| GS52             | 42                | 40 | 32 |
| GS53             | 43                | 41 | 33 |
| GS54             | 44                | 42 | 34 |
| GS55             | 45                | 43 | 34 |
| GS56             | 45                | 44 | 35 |
| GS57             | 46                | 44 | 35 |
| GS58             | 47                | 45 | 36 |
| GS59             | 48                | 46 | 37 |
| GS60             | 49                | 47 | 37 |
| GS61             | 49                | 48 | 38 |
| GS62             | 50                | 48 | 39 |
| GS63             | 51                | 49 | 39 |
| GS64             | 52                | 50 | 40 |
| GS65             | 53                | 51 | 41 |
| GS66             | 54                | 52 | 41 |
| GS67             | 55                | 53 | 42 |
| GS68             | 56                | 54 | 43 |
| GS69             | 57                | 55 | 44 |
| GS70             | 58                | 56 | 45 |
| GS71             | 59                | 57 | 46 |
| GS72             | 60                | 58 | 46 |
| GS73             | 62                | 59 | 47 |
| GS74             | 63                | 60 | 48 |
| GS75             | 64                | 61 | 49 |
| GS76             | 65                | 62 | 50 |
| GS77             | 66                | 63 | 51 |
| GS78             | 67                | 64 | 51 |
| GS79             | 68                | 65 | 52 |
| GS80             | 70                | 66 | 53 |
| GS81             | 71                | 68 | 54 |
| GS82             | 72                | 69 | 55 |
| GS83             | 73                | 70 | 56 |
| GS84             | 74                | 71 | 57 |
| GS85             | 75                | 72 | 58 |

| Input Gray scale | Output Gray scale |     |     |
|------------------|-------------------|-----|-----|
|                  | R                 | G   | B   |
| GS86             | 77                | 73  | 58  |
| GS87             | 78                | 74  | 59  |
| GS88             | 79                | 75  | 60  |
| GS89             | 80                | 77  | 61  |
| GS90             | 82                | 78  | 62  |
| GS91             | 83                | 79  | 63  |
| GS92             | 84                | 80  | 64  |
| GS93             | 85                | 81  | 65  |
| GS94             | 86                | 82  | 66  |
| GS95             | 88                | 83  | 67  |
| GS96             | 89                | 85  | 68  |
| GS97             | 90                | 86  | 69  |
| GS98             | 91                | 87  | 70  |
| GS99             | 93                | 88  | 71  |
| GS100            | 94                | 89  | 72  |
| GS101            | 95                | 91  | 73  |
| GS102            | 96                | 92  | 74  |
| GS103            | 98                | 93  | 75  |
| GS104            | 99                | 94  | 76  |
| GS105            | 100               | 95  | 77  |
| GS106            | 101               | 97  | 78  |
| GS107            | 103               | 98  | 79  |
| GS108            | 104               | 99  | 80  |
| GS109            | 105               | 100 | 81  |
| GS110            | 106               | 102 | 82  |
| GS111            | 108               | 103 | 83  |
| GS112            | 109               | 104 | 84  |
| GS113            | 110               | 105 | 85  |
| GS114            | 112               | 107 | 86  |
| GS115            | 113               | 108 | 87  |
| GS116            | 114               | 109 | 88  |
| GS117            | 115               | 111 | 89  |
| GS118            | 117               | 112 | 90  |
| GS119            | 118               | 113 | 91  |
| GS120            | 119               | 114 | 92  |
| GS121            | 121               | 116 | 93  |
| GS122            | 122               | 117 | 94  |
| GS123            | 123               | 118 | 96  |
| GS124            | 125               | 120 | 97  |
| GS125            | 126               | 121 | 98  |
| GS126            | 127               | 122 | 99  |
| GS127            | 129               | 124 | 100 |
| GS128            | 130               | 125 | 101 |
| GS129            | 131               | 126 | 102 |
| GS130            | 133               | 128 | 103 |
| GS131            | 134               | 129 | 104 |
| GS132            | 135               | 130 | 106 |
| GS133            | 137               | 132 | 107 |
| GS134            | 138               | 133 | 108 |
| GS135            | 139               | 134 | 109 |
| GS136            | 141               | 135 | 110 |
| GS137            | 142               | 137 | 111 |
| GS138            | 143               | 138 | 112 |
| GS139            | 145               | 139 | 113 |
| GS140            | 146               | 141 | 115 |
| GS141            | 147               | 142 | 116 |
| GS142            | 149               | 143 | 117 |
| GS143            | 150               | 145 | 118 |
| GS144            | 151               | 146 | 119 |
| GS145            | 153               | 147 | 120 |
| GS146            | 154               | 149 | 122 |
| GS147            | 155               | 150 | 123 |
| GS148            | 157               | 151 | 124 |
| GS149            | 158               | 153 | 125 |
| GS150            | 160               | 154 | 126 |
| GS151            | 161               | 155 | 127 |
| GS152            | 162               | 157 | 129 |
| GS153            | 164               | 158 | 130 |
| GS154            | 165               | 159 | 131 |
| GS155            | 166               | 161 | 132 |
| GS156            | 168               | 162 | 133 |
| GS157            | 169               | 163 | 135 |
| GS158            | 170               | 165 | 136 |
| GS159            | 172               | 166 | 137 |
| GS160            | 173               | 167 | 138 |
| GS161            | 174               | 168 | 139 |
| GS162            | 176               | 170 | 140 |
| GS163            | 177               | 171 | 142 |
| GS164            | 178               | 172 | 143 |
| GS165            | 179               | 173 | 144 |
| GS166            | 180               | 174 | 145 |
| GS167            | 181               | 175 | 146 |
| GS168            | 182               | 176 | 147 |
| GS169            | 183               | 177 | 148 |
| GS170            | 184               | 179 | 149 |
| GS171            | 186               | 180 | 150 |

| Input Gray scale | Output Gray scale |     |     |
|------------------|-------------------|-----|-----|
|                  | R                 | G   | B   |
| GS172            | 187               | 181 | 151 |
| GS173            | 188               | 182 | 152 |
| GS174            | 189               | 183 | 154 |
| GS175            | 190               | 184 | 155 |
| GS176            | 191               | 185 | 156 |
| GS177            | 192               | 186 | 157 |
| GS178            | 193               | 187 | 158 |
| GS179            | 194               | 188 | 159 |
| GS180            | 195               | 189 | 160 |
| GS181            | 196               | 190 | 161 |
| GS182            | 197               | 191 | 162 |
| GS183            | 197               | 192 | 163 |
| GS184            | 198               | 193 | 164 |
| GS185            | 199               | 194 | 165 |
| GS186            | 200               | 195 | 166 |
| GS187            | 201               | 196 | 167 |
| GS188            | 202               | 197 | 168 |
| GS189            | 203               | 198 | 169 |
| GS190            | 204               | 199 | 170 |
| GS191            | 205               | 199 | 171 |
| GS192            | 205               | 200 | 172 |
| GS193            | 206               | 201 | 173 |
| GS194            | 207               | 202 | 175 |
| GS195            | 208               | 203 | 176 |
| GS196            | 209               | 204 | 177 |
| GS197            | 210               | 205 | 178 |
| GS198            | 211               | 206 | 179 |
| GS199            | 212               | 207 | 180 |
| GS200            | 213               | 208 | 181 |
| GS201            | 214               | 209 | 182 |
| GS202            | 215               | 210 | 184 |
| GS203            | 216               | 211 | 185 |
| GS204            | 217               | 212 | 186 |
| GS205            | 217               | 213 | 187 |
| GS206            | 218               | 214 | 188 |
| GS207            | 219               | 215 | 189 |
| GS208            | 220               | 216 | 190 |
| GS209            | 221               | 217 | 192 |
| GS210            | 222               | 218 | 193 |
| GS211            | 223               | 219 | 194 |
| GS212            | 224               | 220 | 195 |
| GS213            | 225               | 221 | 196 |
| GS214            | 225               | 222 | 197 |
| GS215            | 226               | 223 | 198 |
| GS216            | 227               | 224 | 200 |
| GS217            | 228               | 225 | 201 |
| GS218            | 229               | 226 | 202 |
| GS219            | 230               | 227 | 203 |
| GS220            | 231               | 228 | 204 |
| GS221            | 231               | 229 | 205 |
| GS222            | 232               | 230 | 207 |
| GS223            | 233               | 231 | 208 |
| GS224            | 234               | 232 | 209 |
| GS225            | 235               | 233 | 210 |
| GS226            | 236               | 234 | 211 |
| GS227            | 236               | 235 | 213 |
| GS228            | 237               | 236 | 214 |
| GS229            | 238               | 237 | 215 |
| GS230            | 239               | 238 | 216 |
| GS231            | 240               | 239 | 217 |
| GS232            | 241               | 240 | 219 |
| GS233            | 241               | 240 | 220 |
| GS234            | 242               | 241 | 221 |
| GS235            | 243               | 242 | 223 |
| GS236            | 243               | 243 | 224 |
| GS237            | 244               | 243 | 226 |
| GS238            | 245               | 244 | 227 |
| GS239            | 246               | 245 | 229 |
| GS240            | 246               | 246 | 231 |
| GS241            | 247               | 246 | 232 |
| GS242            | 248               | 247 | 234 |
| GS243            | 248               | 248 | 235 |
| GS244            | 249               | 249 | 237 |
| GS245            | 250               | 249 | 239 |
| GS246            | 250               | 250 | 240 |
| GS247            | 251               | 251 | 242 |
| GS248            | 251               | 251 | 244 |
| GS249            | 252               | 252 | 245 |
| GS250            | 253               | 253 | 247 |
| GS251            | 253               | 253 | 249 |
| GS252            | 254               | 254 | 250 |